

S1/S2/S3
Series
VII

The Split Makes the Difference

CRAFT BEARING

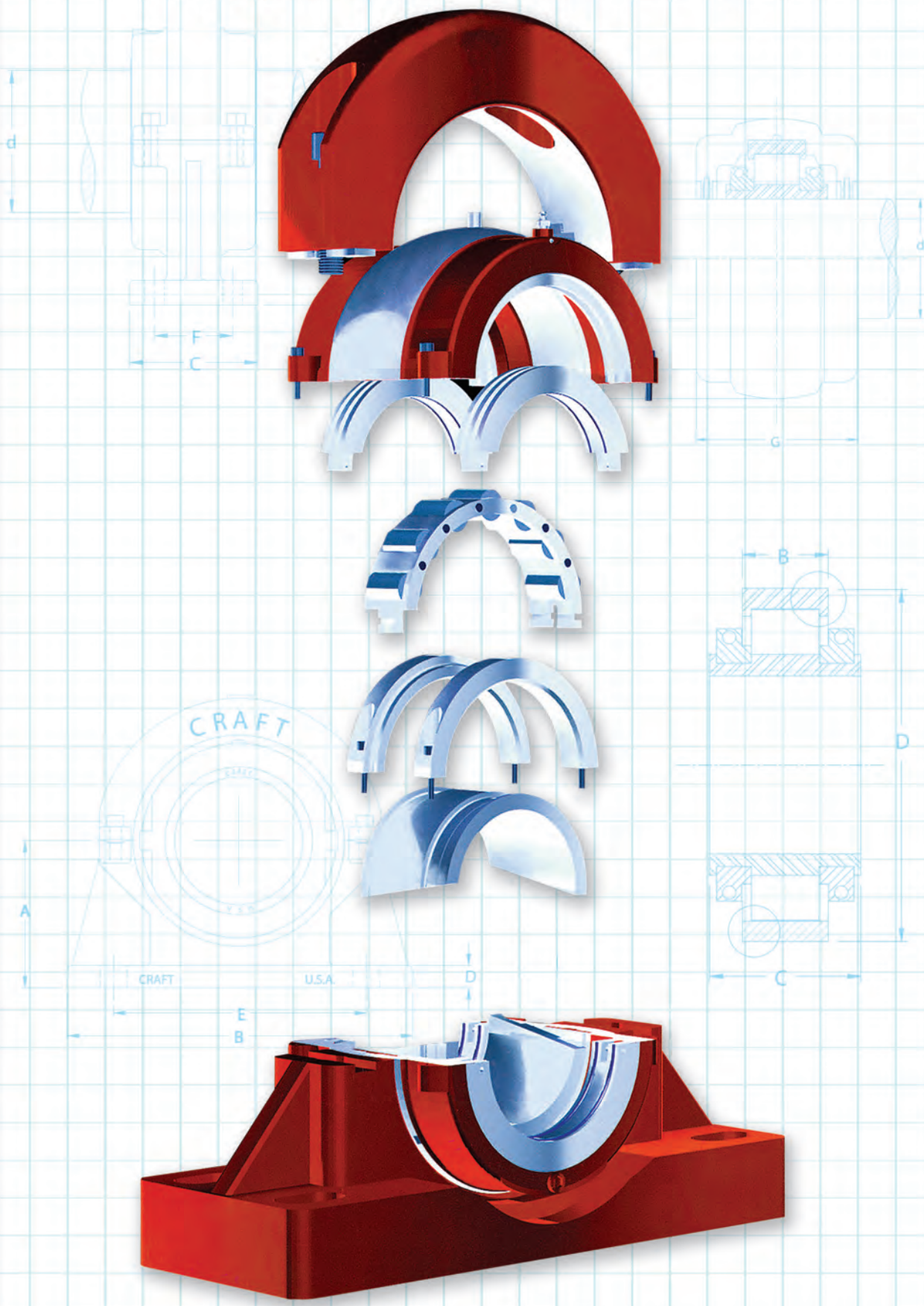

CRAFT
Bearing Company Inc.



Profits drying up? Maybe it's time for some American Craft

When your water is not flowing due to downtime, chances are neither is your profit. Craft Split Roller Bearings are the answer.

Our American-made Split Roller Bearings are built to last longer than other bearings. And, in addition to rapid installation, downtime is greatly reduced due to the accessibility of the bearing. This means you're up and flowing sooner.

The water and waste industry is greatly benefitting from our split roller bearings with applications in flocculators, rotary aerators, conveyors, RBCs, CBCs, screens, rakes and fans.

Craft Split Roller Bearings give you reliability and accessibility backed by exceptional customer service and technical support!

Count on Craft to supply your next bearing order.

- Standard base-to-center height
- Metric, special applications and custom bearings also available
- Bore sizes from 1-7/16" to 32", same day shipment through 12"
- Ductile iron castings standard
- Complete technical support
- Rapid response to larger sizes and special orders
- Made in USA

CRAFT



Bearing Company Inc.

5000 Chestnut Avenue ■ Newport News, VA 23605

PHONE (757) 247-6000

FAX (757) 247-6300

EMAIL info@craftbearing.com

WEBSITE www.craftbearing.com

■ Advantages of the Craft Split Roller Bearing	3
■ Proven Solutions	4
■ Bearing Components and Features	5
The Bearing Assembly	5
Rollers, Inner Race and Outer Race	5
Clamp Collars	5
Roller Cage Assembly	5
Triple Labyrinth Seals	5
Cartridges and Housings	6
Craft's Split Bearing Cartridges	6
Craft's Split Bearing Housings	6
Craft's Cartridges and Housing Self-aligning	6
Fasteners	6
■ Specialty Components	7
Extended Inner Race	7
■ Bearing Types	8
Held Bearings	8
Float Bearings	8
■ Selecting the Correct Bearing	9
Shaft Size and Tolerance	9
Product Dimensions	9
Bearing Life	9
■ Nomenclature Breakdown	10
■ Lubrication	11
Oil	11
Grease	11
Quantity of Grease	11
Grease Fill Capacity	12
Grease Compatibility	13
Friction Reducing Anti-Seize Compounds	14
Regular Maintenance	14
■ Installation Guide for Craft Split Roller Bearings	15
Tool List	15
1. Check the Shaft	15
2. Bearing Installation Preparation	15
3. Installing the Triple Labyrinth Seals	16
4. Installing the Inner Race with Clamp Collars	16
5. Installing the Roller Cage Assembly	18
6. Installing the Outer Race	18
7. Installing the Cartridge	19
8. Installing the Pedestal Housing	20
■ Summary	21
■ Torque Specifications	22-23
■ Bearing Frequency Data	24-25
■ S1 Bearing Dimensions	26-31
■ SN Compatible Dimensions	32
■ S1 Series Load Chart Ratings	33
■ S2 Bearing Dimensions	34-39
■ SAF Compatible Dimensions	40
■ S2 Series Load Chart Ratings	41
■ S3 Bearing Dimensions	42-43
■ Application Data Sheet	44

CRAFT SPLIT BEARINGS combine the features of conventional anti-friction cylindrical roller bearings with the added benefit of being easily assembled around a shaft. The complete assembly is engineered and manufactured in halves, with the results being ease of installation and inspection with minimal to no disturbance of other elements. The risk of adjacent equipment damage or re-alignment is eliminated as they are not disturbed. Readily available, simple, and inexpensive hand tools are all that is required to install Craft split bearings.

Machine design can be made more efficient and focused on objectives without having to accommodate bearings with more difficult replacement requirements. Standard straight shafting can be used—eliminating the costs of special machining, tools, and procedures often associated with other bearings. Maintenance, downtime, and lost production costs are greatly reduced for the entire life cycle of your equipment. This reduced cost and savings by utilizing Craft split bearings is transferred directly to your bottom line.

The design, quality of materials, and manufacturing process of Craft split bearings are such that reliability and long life are assured.

All Craft split bearings are available in inch as well as metric bore. Special and one-off sizes are available with fast turnaround. These are just a few inherent design features and advantages of the Craft split bearing described herein.

CRAFT
Bearing Company Inc.

PHONE +1 (757) 247-6000
FAX +1 (757) 247-6300
EMAIL info@craftbearing.com
WEBSITE www.craftbearing.com

The Split Makes the Difference

MADE IN THE U.S.A.

- **Split to the shaft construction** – for ease of installation and maintenance.
- **Made in the USA** – designed, manufactured, warehoused in Newport News, Virginia.
- **Self-Aligning** – the bearing cartridge and housing externally self adjust to handle up to 3 degrees of misalignment, as standard.
- **Manufactured of through-hardened 52100 bearing steel** (rollers, inner and outer races).
- **Ductile iron standard** – Cartridges, pedestal, and flange housings are machined from high strength 65-45-12 ductile iron and steel is available upon request.
- **Powder coated finish** – (baked on) for cartridges and housings.
- **Drain plugs** – on cartridges to allow purging of grease.
- **Socket head hardware** – SAE standard, grade 8.
- **Triple labyrinth seals** – Feature dovetail groove design to fully retain the O-ring material, allowing the seal to rotate with shaft to avoid shaft wear and provide superior sealing.
- **Patented roller cage** – The roller cage has cylindrical pockets that encapsulate the rollers and maintain an even spacing between rollers. Small sizes feature “Zamak 3” or aluminum. The cage performs as a one-piece cage when installed.
- **Bronze roller cages** – From 4” and up in the S1 series, and all S2 and S3 series bearings, the cages are made from 932 bearing bronze. These cages are assembled with a bolted lap joint and utilize high tensile Nylock screws.
- **Economic advantage** – Higher quality and longer life.
- **Float (expansion) and held (non-expansion) bearing** are the same price.
- **Three progressively heavier duty groups** – S1, S2, and S3 series to best suit load, life, and speed requirements.
- **Most sizes are available from stock for immediate shipment** – Normal inch sizes (1⁷/₁₆” – 12”) and metric (40 mm – 300 mm) are in stock. Larger sizes to 32”, and special designs are available upon request.
- **Cylindrical Bore Bearings** – “Straight from the shelf” standard shafting can be used, greatly reducing costs in machine design, build, and maintenance.
- **Custom Work** – special application bearings, housings, and cartridges are available upon request.
- **Lloyd’s Register Type Approved and U.S. Dept. of Defense Approved.**
- **Full factory support.**

CRAFT SPLIT ROLLER BEARINGS have been solving the problems of even the heaviest end of industry—where continuous duty, high reliability under harsh conditions, and minimum maintenance and downtime are critical. The following represents but a few of the numerous types of machinery and industries where Craft split bearings have proven successful and can be a benefit to your bottom line.

- **Mining/Aggregate/Asphalt/Ready Mix:** Cleaning, processing, general mineral extraction—fans, conveyors, bucket elevators, mine hoist gearing, crushers and pulverizers, flotation cells, ball and rod mills, pug mills, cage mills, hammer mills, reciprocating screens, gen sets, etc.
- **Coke, Iron and Steel:** Coal crushers, drag conveyors, roll out tables, cooling beds, transfer beds, mill drives, overhead cranes, bag house fans, primary air fans, charging car conveyors, etc.
- **Cement Production:** Clinker crushers, clinker coolers, conveyors, fans (bag house, kilns, etc.), bucket elevators, ball and rod mills.
- **Marine:** Fans, propulsion shafting, thrusters, gearboxes, winches, conveyors.
- **Sugar, Beet and Cane:** Cane knives, carriers and feeders, shredders, crushers, belt conveyors, line shafts, washers, fans, press rolls, pulp shredders, and bucket elevators.
- **Grain Processing, Flour Mills, Foods:** Line shafting, fans, bucket elevators, other conveyor types, man lift, dewatering presses, tube bundle and other rotary dryers, rotary cookers, etc.
- **Large electric motors (mill drives, etc.) and generator sets for auxiliary/emergency power.**
- **Pulp and Paper:** Mixers, conveyors, agitators, fans, log decks, chip conveyors, wood hogs, calendar and press rolls, paper drying cylinders, re-winders, line shafting, and pulp washers.
- **Lumber:** Dry kilns, OSB ovens, log decks, chain and belt conveyors, fans, wood hogs, grinders, etc.—in dimensional lumber, chipboard, OSB, and plywood veneer plants.
- **Power Generation:** Ball Mills, FD and ID fans, belt conveyors, barge unloaders, crushers, pulverizers, damper doors, coal breakers, generator sets, pumps, water inlet screens, motor generator sets, horizontal/vertical hydro electric generators.
- **Water and Wastewater Treatment:** Paddle wheel and rocker arm mechanical flocculators, rotary and disc aerators, RBCs, CBCs, tank scrapers, rotary/bar screens, collectors, sludge presses, skimmers, conveyors, fans, pumps, drum screens, etc.
- **Chemical, Pharmaceutical, Petro-chemical, etc.:** Fin fans, air handlers, pumps, line shafts, conical, vee, and double cone dryers, vacuum dryers, ribbon and paddle blenders, and others.

THE COMPLETE BEARING consists of components that can be purchased separately or as a complete pillow block. The components include the **bearing assembly** (the inner race, the clamp collars that hold the inner race halves in place, the roller cage with rollers, and the outer race); the **seals** which protect the bearing from dirt and contaminants; the **cartridge** which contains the bearing assembly; and the **housing** (pedestal or flange) units which support the cartridge and holds cartridge and bearing assembly in the correct position and height.

■ The Bearing Assembly

Rollers, inner race and outer race are made from through-hardened 52100 bearing steel. With Craft's standard through-hardened practices, this high carbon chrome, low alloy steel provides excellent load bearing strength and wear characteristics, superior surface quality, and an inherent ability to withstand impact load conditions. Strict statistical process control used throughout manufacturing assures tolerance accuracy, fine surface finish, and consistent high quality.

Clamp Collars are made from various mild steels—dependent upon bearing size and series. The materials used are chosen for their ability to be hardened yet retain the ductility required for the repetitive stresses involved with dynamic and constantly varying loads, for millions of stress cycles. The clamp collars' seat serves two purposes, to lock the inner race to the shaft and to guide the rollers along the inner race.

Roller Cage Assembly is available in two types. In the S1 series to 3½ inch group, Craft roller cages are made from Zamak 3 or aluminum material. Zamak is zinc-aluminum alloy with

desired high lubricity and stiffness qualities. The cage joints for the zamak are a tongue and groove design and spring steel cage clips are supplied to fasten the cage halves together at installation.

Craft roller cages 4 inch bore and over in S1 series, and in all S2 and S3 series bearings, are made from 932 bearing bronze as standard. Cage joining faces are made with a special "Z" cut to create an overlapping design. The cage halves are secured by counter sunk high tensile socket cap screws, and the screws come with a thread-locking compound built into the screw (Nylok) that ensures retention of the screws for the life of the bearing.

All of Craft's roller cages are designed with cage pockets to encapsulate the rollers to retain lubricant and ensure accurate roller guidance while possessing extremely low wear characteristics. Once the cage halves are mated and secured around the inner race, the units perform as a solid roller cage.

■ Triple Labyrinth Seals

Craft's aluminum triple labyrinth (ATL) seals are made from 6061-T6 marine grade/aircraft grade aluminum. The seal bore is machined to accept and retain a double row of molded O-ring material. This provides 100% sealing between the shaft and the bore, as well as allows for shaft movement for expansion and contraction during operation without compromising the seal. By design, the seals rotate with the shaft—this prevents shaft wear at the seal/shaft mating seat, ensuring long life and full sealing capability.

Depending on the application, various O-ring materials are available as an application may require. The seals can be made from other materials such as UHMW, bronze, or stainless steel.

■ Cartridges and Housings

CRAFT'S CARTRIDGES AND HOUSINGS are made of 65-45-12 ductile iron as standard. Ductile iron was selected because it provides the attributes of steel—high load, superior shock and wear resistance, and low and high temperature endurance. A powder coat finish is applied to all ductile iron components which provides a more durable and longer lasting finish when compared to the paint. Other coating types are available as an application may demand. Steel is also available for special applications as well as custom designs for a unique machine.

Bearing cartridges are designed to provide a rigid mounting for the bearings and seals which protect the bearing from contaminants. The labyrinths machined into the cartridges accept the seal O.D. labyrinths, and they are lubricated with grease to further enhance sealing capability and lubricate the rotating seals during operation. The cartridge also acts as a lubricant reservoir for the bearing components with a purge hole as standard on all cartridges.

Bearing housings are available as a pedestal for mounting on a surface parallel to the shaft, and flanges for mounting on a surface perpendicular to the shaft. The housing is designed for ease of installation and alignment of shaft and equipment. In addition to the standard sizes in stock, special sizes and shapes are available to satisfy the customer's needs.

Self-alignment between the cartridge and housing allows for 3 degrees per side of initial shaft misalignment. A major cause of premature bearing failure is misalignment which can be caused by misalignment at installation, machine movement, temperature changes, and other factors. The inside diameter of the housings are spherically machined to match the spherical outside of the cartridge assembly. When the pieces are mounted as an assembly, this creates an external self-aligning capability for the

complete assembly. To properly facilitate the ball and socket design, the machined surfaces are lubricated at assembly with an anti-seize or moly-based compound that serves to both lubricate and protect the machined surfaces in operation.

Since the complete bearing assembly is within the cartridge, the external self-alignment allows the bearing and seals to properly align with the shaft, thus allowing the bearing to perform optimally. Craft split bearings are designed to address the major causes of bearing failure, misalignment and contamination.

■ Fasteners

Grade 8, high tensile steel alloy (hardened and tempered) "Allen" head fasteners are used in Craft split bearings. S.A.E. threads are standard. Metric is available upon request. Stainless steel fasteners (external) are available. Fastener sizes, strengths, and torque specifications are in the charts provided herein.

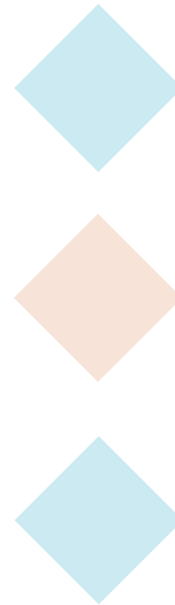

Extended Inner Race

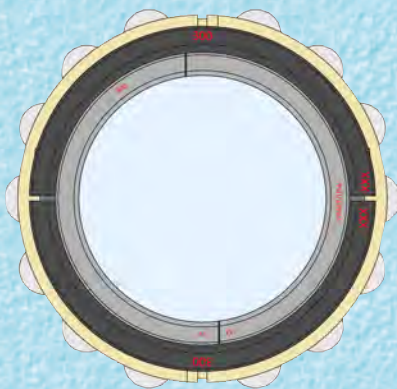
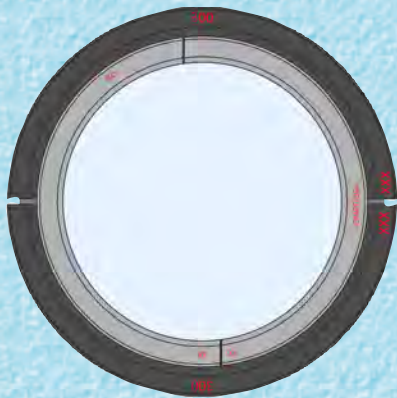
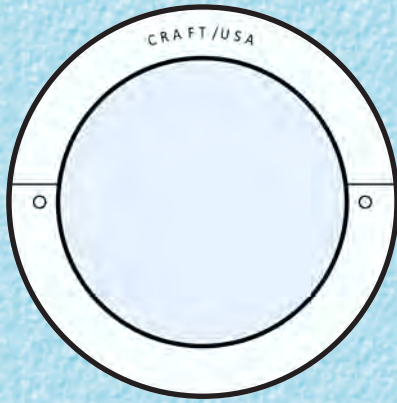

CRAFT SPLIT BEARING'S standard ATL seals (discussed below) eliminate shaft wear and provides exceptional sealing in most applications. However, bearings are sometimes exposed to extreme conditions such as an existing shaft that has grooves or roughness caused by prior bearings with lip seals or other seals that do not turn with the shaft or otherwise cut into the shaft surface. Extremely abrasive conditions can also cause grit or other contaminants to work under the O-rings and damage the seals or shaft.

Craft's extended inner race, only available from Craft (patent pending), is a valuable option in those cases where a damaged shaft or extreme conditions would require shaft repair or replacement. The inner race is lengthened under the seal, with

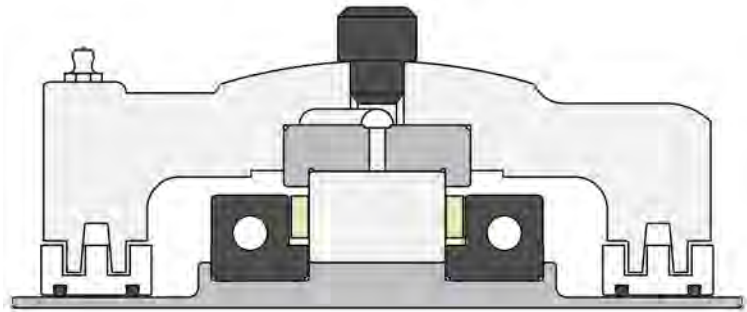

a machined track for the seal to clamp to the inner race—not the shaft. This not only overcomes the problem of grooves or roughness in the shaft caused by prior conventional bearings, it protects against further shaft damage.

As always, the shaft must be clean, round, within tolerance, and without high spots. The Craft extended inner race will cover the normally encountered grooves, rough surfaces, and gouges in a shaft commonly caused by prior conventional bearings. Contact our technical department for any questions.

CRAFT SPLIT ROLLER BEARINGS, in all shaft sizes and series, are manufactured in two types—held and float (fixed and expansion). They are manufactured as separate bearings to solve the problem of applications needing to allow for shaft expansion, and others needing to be able to locate the shaft in a fixed axial position.

■ Held Bearing (HD)

The held bearing accepts both radial (perpendicular to the shaft) and axial (parallel to the shaft) loads. The main purpose of the held bearing is to “locate” a shaft in position, to prevent shaft drift during operation, and absorb thrust or “side” load imposed by the equipment in operation. The held bearing is normally mounted on the drive side, or drive end of a piece of equipment, directing shaft expansion away from the drive. In applications where a high thrust load is expected or realized, please contact our technical department for advice on proper bearing selection.

■ Float Bearing (FL)

The float or “expansion” bearing is designed to take radial (perpendicular) load only. It is designed to allow for thermal growth of a shaft during operation. The floating bearing is normally mounted opposite the drive end of a shaft and used in conjunction with a held or fixed bearing when both bearings are mounted on a common shaft section.

In most applications, one of each type bearing is mounted to a solid shaft section. In the instance of long line shafting, one held bearing is normally used with the rest being floating type. Exact placement of the bearings can vary. It is never advisable to mount two held bearings on the same shaft section.

When using both floating and held type Craft bearings in an application, be sure to maintain individual bearing components of each type separately as they are shipped. Bearing parts are not interchangeable, and individual bearing components are manufactured—and matched—at our plant for proper internal clearance and fit. Mixing components during installation may cause less than desirable performance or premature failure.

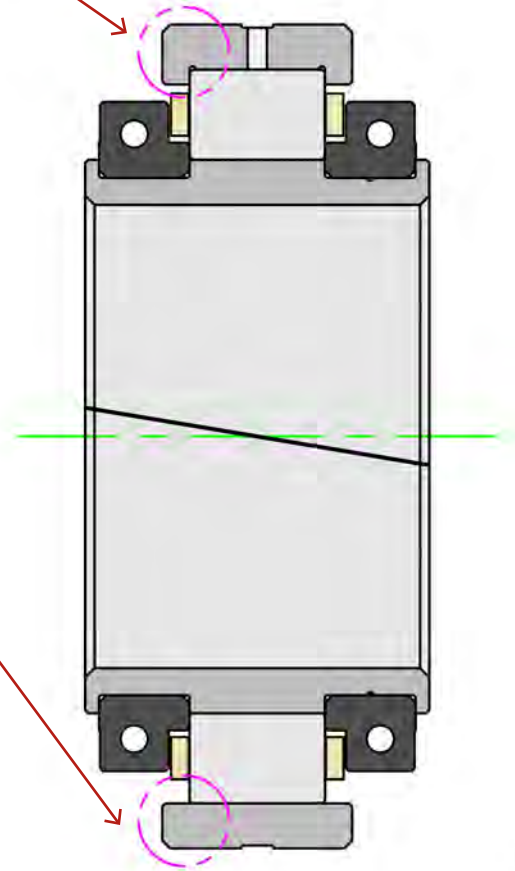

CRAFT BEARING makes a standard duty (S1 series), heavy duty (S2 series), and an extra heavy duty (S3 series) bearings. Bearings from 1½ to 12 inch (or equivalent metric size) are standard stocking items. Larger bearings are often in stock, but special orders can quickly be provided for bearings up to 32 inches.

■ Shaft Size and Tolerance

Craft split bearings are designed and manufactured to a close tolerance. Over time, actual shaft diameter in the field can vary by as much as a few thousandths of an inch in different bearing positions on a single shaft. Shaft to bearing fit becomes more critical as load and/or speed increases. Before mounting a bearing, the journal should be checked for diameter, roundness, taper, and conformity to a straight edge. Roundness and taper should be held within 0.001" along the length and diameter of the bearing seat. The faster an application, the tighter the shaft tolerance should be.

In an engineered piece of equipment such as a roller bearing, shaft tolerance and condition are of highest importance. A bearing is no better than the shaft it is on. Therefore, shaft condition directly affects bearing performance and life.

■ Product Dimensions

In ordering a bearing for a particular application, it may be necessary to know the bearing dimensions (height, width, length). Additionally, the expected load and RPM of the application determines the bearing series need (S1, S2, or S3). The Bearing Dimension section, starting on page 26, provides dynamic, static, and axial load ratings and maximum speed for each bearing size and series.

■ Bearing Life

All calculations to determine the load carrying capacities of the Craft split bearing are based on and in accordance with ABMA and International Organization for Standardization (ISO) standards. Bearing life is a fatigue calculation that estimates the ability of a bearing to carry a load, commonly known as L10. The L10 is the basic life rating of a bearing, generally given in hours or millions of revolutions, and is the minimum expected life for 90% of a group of like bearings. Median life is where 50% of the group will complete or exceed the life rating, and is approximately five times the life rating.

<i>dn</i> value (in.)	Tolerance
0 – 2,000 <i>dn</i>	+ 0.000" / - 0.004"
2,000 – 4,000 <i>dn</i>	+ 0.000" / - 0.003"
4,000 – 6,000 <i>dn</i>	+ 0.000" / - 0.002"
6,000 – 8,000 <i>dn</i>	+ 0.000" / - 0.001"
8,000 and over <i>dn</i>	+ 0.000" / - 0.0005"

Where *dn* = shaft diameter (in.) × RPM, Craft's tolerances for shaft fit are within the generally accepted ABMA/ISO norms of all rolling element bearings, with due respect given for speed capability and uniqueness of design. Craft bearing's speed capability is closely comparable to that of ball bearings in a like shaft size.

$$L_{10} = \left(\frac{C_R}{P_R}\right)^p \times \left(\frac{16667}{n}\right) = \text{Basic life rating in hours.}$$

$$L_{10} = \left(\frac{C_R}{P_R}\right)^p = \text{Basic life rating in millions of revolutions.}$$

C_R = Basic dynamic load rating

P_R = Dynamic equivalent radial load

p = Exponent of life equation = 10/3

n = Shaft revolutions per minute

In order to simplify bearing size and part identification, all numbers and letters in Craft Bearing's part numbers have a specific descriptive meaning.

Nomenclature	Example
Inch bore sizes are in one inch increments plus the number of sixteenth of an inch. The first one or two numbers are the whole inch and the last two are the number of sixteenth.	203 = 2 ³ / ₁₆ " 900 = 9" 1208 = 12 ⁸ / ₁₆ " (12 ¹ / ₂ ")
Metric Bore Sizes are indicated by the number of millimeters followed by the letters "mm."	S1 BCH 100mm HD S1 BCH 75mm FL
S1 = Medium duty S2 = Heavy duty S3 = Extra Heavy duty S4 = Special duty	The duty series are available to best suit load, life, and speed requirements.
B = bearing only (one split inner race, two split clamp collars, one split roller cage assembly, one split outer race)	S1 B 207 FL S2 B 615 HD S3 B 900 FL
C = cartridge (only) for held or floating bearing type	S1 C 500 S2 C 308
H = pedestal housing (only) for held or floating bearing type	S1 H 208 S2 H 315
F = flange housing (only) for held or floating bearing type	S1 F 208 S2 F 315
BC = bearing-cartridge w/seals (a replacement "insert")	S1 BC 203 FL S2 BC 315 HD
BCH = complete pillow block (bearing-cartridge w/seals and pedestal housing)	S1 BCH 515 FL S2 BCH 515 HD
BCF = complete flange block (bearing-cartridge w/seals and flange housing)	S1 BCF 315 FL S2 BCF 800 HD
FL = floating (expansion) type bearing	S1 BCH 207 FL S2 BCF 415 FL
HD = held (fixed/non-expansion) type bearing	S1 BCH 207 HD S2 BCF 415 HD
ATL = aluminum triple labyrinth seals - two seals per unit (split) UHMWTL = UHMW triple labyrinth seals	ATL 407 ATL 200mm UHMWTL 500
C-2 = less than normal internal clearance (reciprocating loads - crank shafts, etc.) C-3, C-5 = greater than normal internal clearance normally used in high temperature applications, above 200°F use C-3 and above 340°F use C-5 . If no identifier is provided then a C-Normal running clearance will be provided.	S2 B 307 FLC2 S1 BCH 607 HDC3
XX = letter, or number / letter suffix - added to identify special modifications to suit a particular customer's needs, or a special application.	S1 BCH 507 FLXX

Note:

- Bearing sizes to 12" (300 mm) are in normal stock for immediate shipment. Bearing sizes over 12" are available. Please call for price and delivery.
- When ordering seals separate of an assembly, specify the number of seals needed.
- Standard O-ring material is buna nitrile. For high temperature applications, viton O-rings are recommended and are automatically included when C-3 or C-5 clearance is specified.
- Many "special" or otherwise non-standard bore sizes or "one off" pieces can be made upon demand. Please confer with our technical department.

THE MAIN PURPOSE of lubricating a bearing is to coat the rolling contact/load bearing surfaces with a lubricant, minimizing direct metal-to-metal contact. This accomplishes the following:

- Reduces heat, friction and abrasion, prolonging useful life,
- Transports heat away from the load zone (oil),
- Slows or prevents corrosion, and
- Helps reduce the ingress of foreign matter into the bearing (grease).

Proper lubrication during assembly is critical. Please refer to the assembly instructions for lubrication requirements when assembling bearings. Proper lubrication during operation is also critical. The **type** and **quantity** of lubrication depends on the application—the load, RPM, and temperature all affect the needed lubrication. The majority (about 90%) of rolling element bearings are grease lubricated. Oil is generally utilized in high speed and high temperature applications.

Oil

When necessary (above 8,000 dn), oil can be pumped, drained, filtered, cooled and re-circulated. This is very effective in removing heat buildup, prolonging both bearing and lubricant life. Various types of oil lubrication delivery methods are available, such as static, constant level oilers, re-circulating, and oil mist delivery systems. Various additives are available to improve resistance to thinning, oxidation resistance, corrosion resistance, foaming resistance, extreme pressure properties, etc. Consult with a reputable supplier of oil and grease products to better choose the right lubricating oil for a particular application.

Grease

Type of Grease – Grease “stays put”, is easy to handle, easy to meter using simple methods, and is helpful in further sealing a bearing from contaminants and moisture. A widely available, broadly used grease type is NLGI type 2, lithium complex based grease with extreme pressure additives (EP2). This grease type is available with various viscosity oils—hydrocarbon as well as synthetic. Synthetic greases perform well outside the range of standard hydrocarbon based greases, in both low and high temperatures. They also have the ability to retain their lubricating properties for a longer amount of time over standard hydrocarbon greases. Re-lubrication intervals can be extended. When harsh conditions are present or a high degree of reliability is demanded, Craft often recommends synthetics. For most applications, it is standard to use lithium complex, EP2 type grease with ISO VG 220. A consultation with one of many reputable grease suppliers should yield the right grease for the job. **DO NOT MIX GREASES!** The variations in additives between brands and types may cause problems.

Quantity of Grease – More bearings fail prematurely from over greasing than from grease starvation. How much grease is required in a bearing depends mainly on speed. The amount of grease to satisfy the needs of particular sizes and series of Craft bearings is based on the dn value, the product of which is expressed as a percentage of a full pack of grease. A full pack chart for various sizes follows this section. As used herein, $dn = d$ (shaft diameter in inches) $\times n$ (shaft speed in revolutions per minute); for example:

A 3 ⁷ / ₁₆ ” bearing rotating 1400 rpm has a $dn = 4,813$ (3.4375×1400)	[50% pack]
A 4 ¹⁵ / ₁₆ ” bearing rotating 1400 rpm has a $dn = 6,913$ (4.9375×1400)	[33% pack]
A 65 mm bearing rotating 1400 rpm has a $dn = 3,500$ ($[65 / 25.4] \times 1400$)	[75% pack]
A 100 mm bearing rotating 1400 rpm has a $dn = 5,600$ ($[100 / 25.4] \times 1400$)	[50% pack]



■ Grease Fill Capacity

Following is a chart showing the amount of grease it takes to fully pack individual Craft bearings. The chart is divided into group sizes, by series. For larger sizes not shown, or special bearings, consult our technical department. Use the dn chart above to calculate the actual percentage of full pack to apply to your application.



dn value	% of Full Pack
0 – 2,000 <i>dn</i>	100
2,000 – 4,000 <i>dn</i>	75
4,000 – 6,000 <i>dn</i>	50
6,000 – 8,000 <i>dn</i>	33
8,000 and up <i>dn</i>	25 (synthetic grease or oil)

Above 8,000 *dn*, oil lubrication, or a synthetic grease is usually recommended. At very high speeds, oil is better suited than grease, and can be used to remove heat buildup in a bearing. For very low speeds and/or heavy loads, or very high speeds, contact our technical department.

Series	Group	Full Pack Amount
S1	108	2.0 oz
S1	200	3.0 oz
S1	208	5.3 oz
S2		7.5 oz
S1	300	6.3 oz
S2		10.5 oz
S1	308	10.5 oz
S2		1.0 lbs
S1	400	12.7 oz
S2		1.5 lbs
S1	408	14.4 oz
S2		2.0 lbs
S1	500	1.0 lbs
S2		2.6 lbs
S1	508	1.5 lbs
S2		3.1 lbs
S1	600	1.8 lbs
S2		3.2 lbs
S3		5.5 lbs
S1	608	2.0 lbs
S2		3.2 lbs
S3		8.0 lbs
S1	700	2.4 lbs
S2		4.4 lbs
S3		9.0 lbs

Series	Group	Full Pack Amount
S1	800	3.0 lbs
S2		6.0 lbs
S3		12.1 lbs
S1	900	3.1 lbs
S2		8.0 lbs
S3		15.5 lbs
S1	1000	4.2 lbs
S2		9.0 lbs
S3		17.5 lbs
S1	1100	4.3 lbs
S2		10.5 lbs
S3		21 lbs
S1	1200	4.4 lbs
S2		12.0 lbs
S3		23.9 lbs
S1	1300	6.0 lbs
S2		16.0 lbs
S3		26.5 lbs
S1	1400	6.7 lbs
S2		15.9 lbs
S3		33.5 lbs
S1	1500	7 lbs
S2		17 lbs
S3		35.5 lbs
S1	1600	8 lbs
S2		20 lbs

Grease Compatibility

A significant portion of grease lubrication failures can be attributed to mixing greases in a system without taking into consideration compatibility. Different thickener systems can react with each other to modify the physical and chemical structure resulting in the inability to hold or release the base oil. The end result is grease with unknown performance properties including load, shear, temperature stability, etc.

Many factors including environment can impact this reaction. An example is grease used in a cold climate or a chiller room may have a slower reaction rate as compared to a high temperature application. A high-speed bearing may be very sensitive to slight incompatibility as compared to a low speed bearing. Refer to the grease compatibility table below.

Grease incompatibility is due to the additives and base oil, so when changing from one grease system to another, the component should be cleaned if at all possible. If this is not possible, verify the greases are compatible and make an assessment of the application criticality and environment. If the grease thickener and base oil is noted to be compatible, purge or flush out as much of the old grease as possible. It is the end user's responsibility to verify the final application and product compatibility. Use caution as to not over grease.

Compatibility testing is an option, which includes heating and holding grease for a specific time at assumed operating temperature for mixtures of 10:90, 50:50, and 90:10. The grease is then inspected for visual abnormalities and can be tested for penetration and four-ball wear change.

Grease Compatibility Table

LEGEND	Aluminum Complex	Barium Soap	Barium Complex	Bentone (Clay)	Calcium Stearate	Calcium 12 Hydroxy	Calcium Complex	Calcium Sulfonate	Lithium Stearate	Lithium 12 Hydroxy	Lithium Complex	Polyurea	Silica Gel	Sodium Soap
○ Compatible														
△ Borderline														
X Incompatible														
Aluminum Complex		X	X	X	X	○	X	△	X	X	○	X	○	△
Barium Soap	X		N/A	X	N/A	N/A	△	△	△	N/A	△	N/A	○	X
Barium Complex	X	N/A		X	X	○	X	○	X	X	X	X	N/A	X
Bentone (Clay)	X	X	X		○	○	X	X	X	X	X	X	△	X
Calcium Stearate	X	N/A	X	○		○	X	○	○	△	○	X	N/A	N/A
Calcium 12 Hydroxy	○	N/A	○	○	○		△	△	○	○	○	X	N/A	N/A
Calcium Complex	X	△	X	X	X	△		X	X	X	○	△	X	X
Calcium Sulfonate	△	△	○	X	○	△	X		△	△	○	X	△	X
Lithium Stearate	X	△	X	X	○	○	X	△		○	○	X	○	X
Lithium 12 Hydroxy	X	N/A	X	X	△	○	X	△	○		○	X	N/A	N/A
Lithium Complex	○	△	X	X	○	○	○	○	○	○		X	○	X
Polyurea	X	N/A	X	X	X	X	△	X	X	X	X		N/A	X
Silica Gel	○	○	N/A	○	N/A	N/A	X	△	○	N/A	○	N/A		X
Sodium Soap	△	X	X	X	N/A	N/A	X	X	X	N/A	X	X	X	

Base Oil Compatibility Table

LEGEND	Mineral Oil	Ester Oil	Polyglycol Oil	Silicone Oil (methyl)	Silicone Oil (phenyl)	Polyphenyl Ether Oil	Perfluorinated Aliphatic Ether Oil
○ Compatible							
△ Borderline							
× Incompatible							
Mineral Oil		○	×	×	△	×	×
Ester Oil	○		○	×	○	○	×
Polyglycol Oil	×	○		×	×	×	×
Silicone Oil (methyl)	×	×	×		△	×	×
Silicone Oil (phenyl)	△	○	×	△		○	×
Polyphenyl Ether Oil	×	○	×	×	○		×
Perfluorinated Aliphatic Ether Oil	×	×	×	×	×	×	

Friction Reducing Anti-Seize Compounds

An anti-seize compound must be used on the spherical of the cartridge and housing to assure continued self alignment and prevention of fretting corrosion—which is caused by two heavily loaded metal surfaces rubbing or vibrating against one another, resulting in the formation of rust. Anti-seize compounds are available as copper base or nickel base metallic type and Teflon based types. In marine applications, nickel based anti-seize is the most common type.



Elastomer Oil Compatibility Table

LEGEND	Seal Material							
	Buna Nitrile	Butyl	Kalrez	Neoprene	Nordel (EPDM)	Silicone	Teflon (PTFE)	Viton
○ Compatible								
△ Borderline								
× Incompatible								
Base Oil	Mineral Oil	○	×	○	○	×	○	○
	Organic Ester	△	×	○	×	×	×	○
	Polyglycol	○	○	○	○	○	○	○
	Phosphate Ester	×	○	○	×	○	○	○
	Silicone	○	○	○	○	○	×	○
	Polybutenes	△	○	○	△	○	○	○
	Fluorinated Ester	○	○	△	○	○	○	○
	Synthesized Hydrocarbon	△	×	○	○	×	×	○
	Chlorofluorinated Hydrocarbon	○	○	○	○	○	○	△
	Content Service Limit (°F)	225	250	550	225	300	450	500

Regular Maintenance

Due to the action of the rollers against the flanges of the clamp collars and the shoulders of the outer raceway, the held bearing requires more frequent lubrication than the float bearing. Held bearings should receive 1/8 ounce (three to four shots) of grease every 250 operating hours, or at two-week intervals. Float bearings should receive 1/8 ounce of grease every 500 hours, or once a month. As a general rule, non-synthetic greases should be cleaned out of the bearings and replenished with new grease annually. By utilizing synthetic grease, this time frame can be extended to three years, dependent on ambient conditions, severity of the application, and re-lube schedules. End user knowledge and experience concerning actual conditions, loads, and speeds, should always be taken into consideration.

■ Tool List

- Micrometer to suit shaft size
- SAE Allen wrench set
- Torque wrench
- Anti-seize compound
- Means to lift and safely support shaft during bearing installation
- Rubber mallet
- Channel locks
- Feeler gauge set
- Strap wrench
- 1/8" diameter straight shank drift pin
- Clean, lint free cloth
- Appropriate viscosity lubricant

1 Check the Shaft

Before mounting any components, the shaft should be checked at the intended location of the bearing for diameter, roundness, taper, and conformity to a straight edge. The tolerance of the shaft's diameter is $+0.000''$ to $-0.004''$, where the $dn < 2,000$, and $+0.000''$ to $-0.002''$, where the $dn > 2,000$. The shaft's roundness and taper tolerance is $\pm 0.001''$ and the surface finish is to be 125 to 63 μin . Remove any rust, nicks, burrs, high spots, and ensure that the shaft is clean and dry before mounting any components. Use the reference images below as a reference for how to check the shaft.

INSTRUCTION #1: Check the Shaft

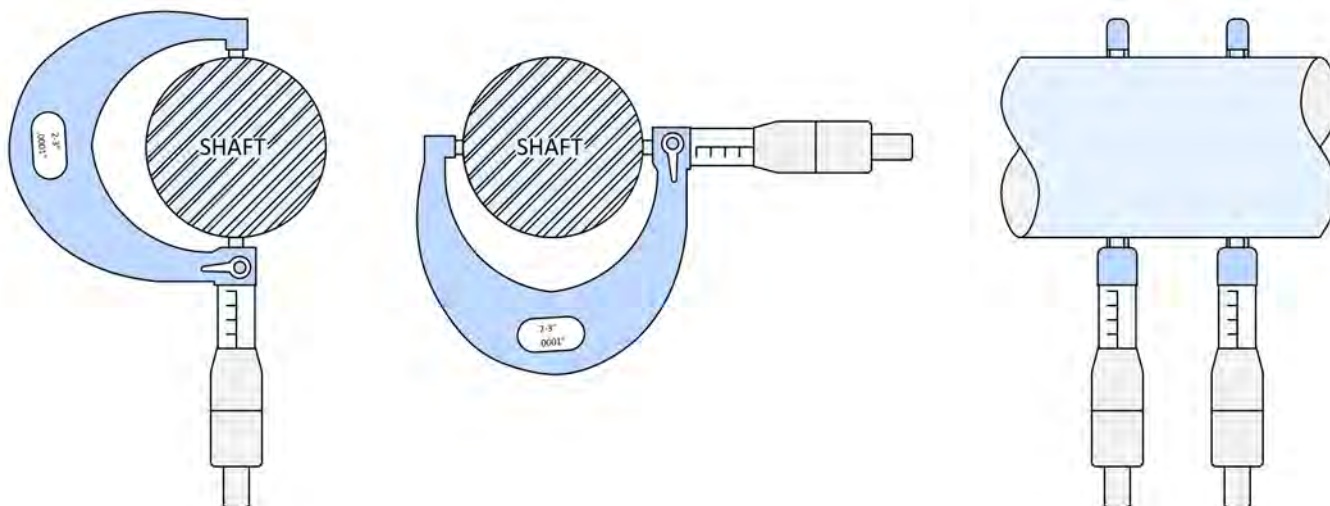

2 Bearing Installation Preparation

Individual bearing components should not be interchanged. The components of each bearing are matched at the factory for proper fit and internal clearance. To facilitate proper assembly, all Craft split bearings are provided with match mark numbers at the mating faces of the individual components. Be sure to completely disassemble the bearing components, remove all protective plastic, and wipe the oil from all surfaces at installation.

The shaft should be raised and fully supported before installing the bearing. It is good practice to locate shaft position, and install the held (fixed) bearing first. This practice serves to anchor the shaft in position and facilitate proper positioning for the expansion bearing on the shaft.

3 Installing the Triple Labyrinth Seals

For best results, install the seals first and slide them out of the way; one seal to the left of, the other seal to the right of, the inner race position on the shaft.

1. Separate the seals by driving out the steel pins with the 1/8" diameter drift pin and pulling the seals apart by hand. Do not mix the two seals up.
2. Lightly lubricate the seal bore between the O-rings with grease.

3. Assemble the seals around the shaft so that "Craft/USA" and the seal bore size are on the same side and facing outward. This will allow for easy identification in the field.
4. A strap wrench may be used to compress the seal together to re-install the steel pins. Use only enough pressure to bring the seal joint faces together. The steel pins can be squeezed back into place with a pair of channel lock pliers.

INSTRUCTION #3: Installing the Triple Labyrinth Seals

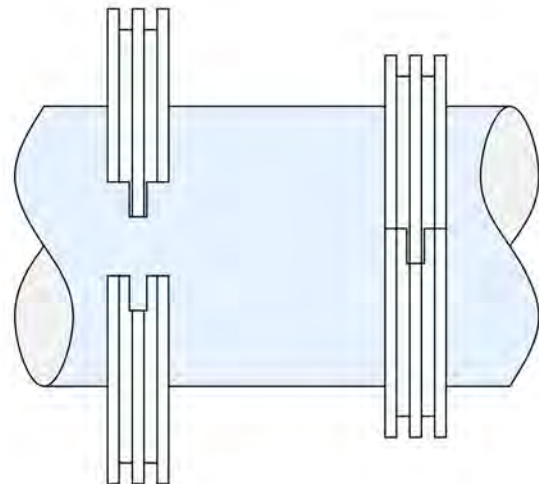
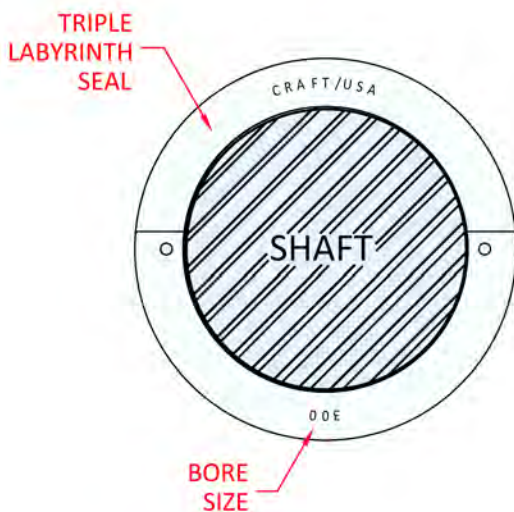

4 Installing the Inner Race with Clamp Collars

Check that the inner race and shaft are clean and dry. Do not coat the shaft or bearing bore with oil or grease. The inner race should be dry fit to the shaft.

1. Observing the match mark numbers, place the inner race halves on the shaft in the desired position. Also note the **black reference line** in the clamp collar groove on one side. Assemble so the **black reference line** is continuous around one

groove. Place the splits in a "north-south" (up-down position).

2. Place a 0.015" feeler gauge in the center of the bottom half of the split. This will prevent the gap from closing up when installing the clamp collars.
3. Install clamp collars with match numbers facing outboard, both sides. Place a non-threaded half of a clamp collar into one

of the machined grooves of the inner race on the top, with its split line at the “east-west” position. The actual position should be between 45 and 90 degrees to the split line of the inner race.

4. Place the bottom half (threaded) of the same clamp collar into position and loosely install the collar locking bolts (fine thread).
5. Repeat the same procedure for the other clamp collar.
6. Re-check inner race position on the shaft before performing the tightening sequence. The race can be moved by tapping it along the shaft with a rubber mallet. **Do not strike the hardened surfaces of the bearing with a hard faced hammer. Permanent bearing damage can occur.**
7. Maintain an equal gap at the joint face of the clamp collars when tightening. Judging

the gaps of the clamp collars “by eye” will suffice.

8. Sequentially tighten all clamp collar bolts. Be sure to remove the feeler gauge as necessary.

There will be gaps at the joint faces of the inner race and clamp collars after final tightening. The gaps are designed to be there, and will vary with shaft size and series of bearings. Provided the shaft is within tolerance, and the race is fully seated on the shaft, the final gap is irrelevant, as long as the gap is evenly split on the inner race halves. However, if there are no gaps at the joints, the shaft is undersized or the bearing bore is incorrect for the shaft. The bearing should not be run. Discontinue installation and re-check the shaft and bearing for matching size before proceeding.

INSTRUCTION #4: Installing the Inner Race with Clamp Collars

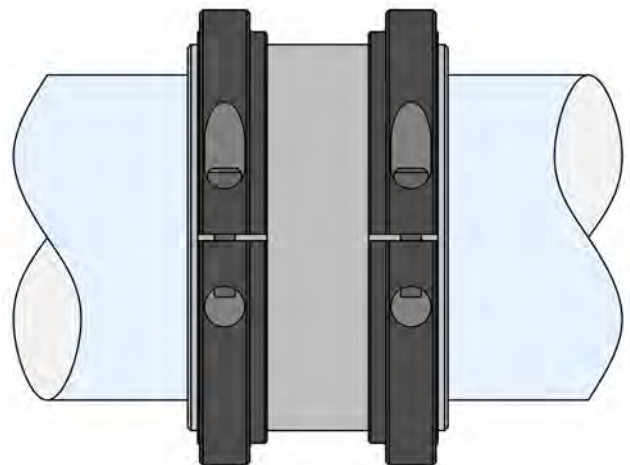
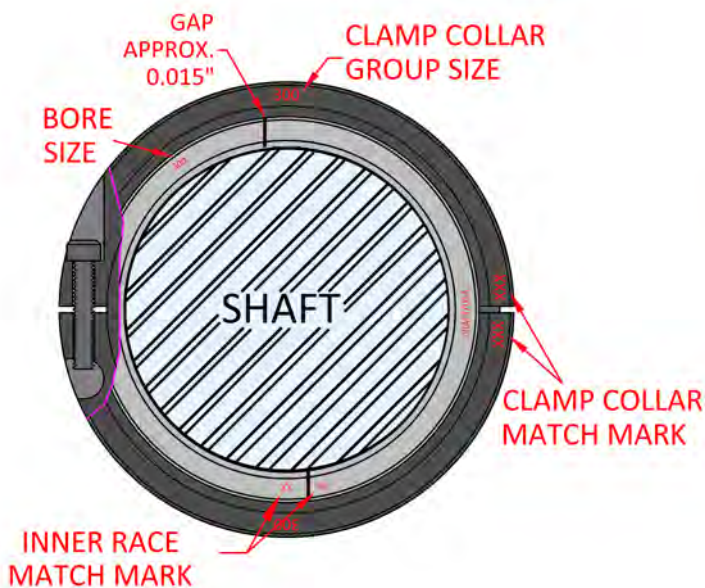

5 Installing the Roller Cage Assembly

1. Wipe the inner race clean of dirt, fingerprints, etc. Apply a light coating of grease to the raceway area.
2. Apply grease to the inner surface area of the roller cage unit. Rotate the rollers while applying grease to allow lubricant to enter the cage pockets.
3. Place cage halves around the inner race. Install the cage clips or Nylok bolts, depending on cage design. Tighten Nylok bolts securely.
4. Lightly coat outer surface of roller and cage with grease. Protect from contamination.

INSTRUCTION #5: Installing the Roller Cage Assembly

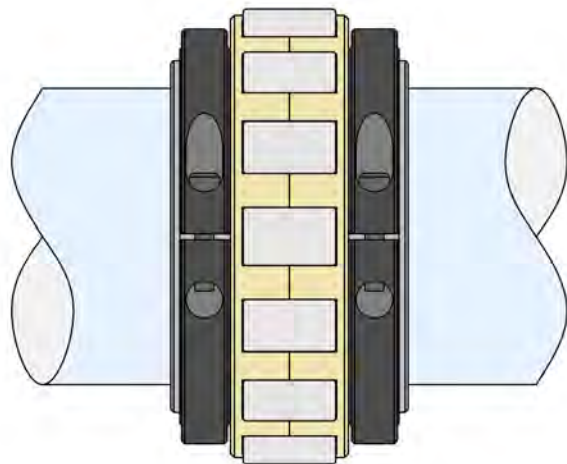
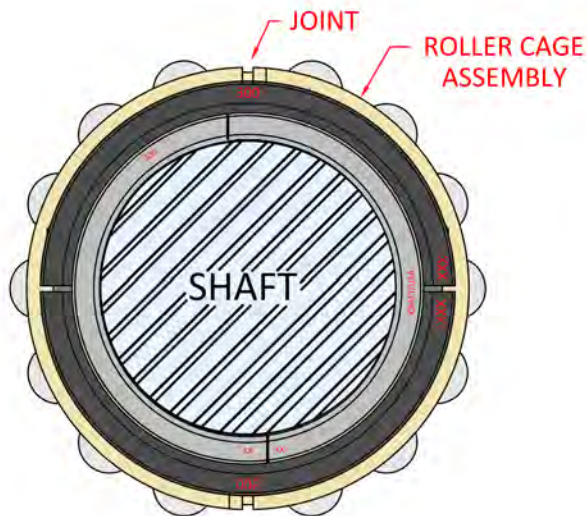

6 Installing the Outer Race

1. Inspect and clean the bore of the cartridge for the outer race, and filling the grease groove in the center of the outer race bore.
2. Inspect and clean the outer race. Take note of the match marks at the joint, and the top half with the lubrication hole.
3. Install the top half of the outer race into the top half of the cartridge. Press firmly into the cartridge bore. Then repeat for the bottom half. Make sure the outer race match marks line up, and that the outer race with the lubrication hole is in the cartridge half with the lubrication zerk. If the bearing is a 6½" group size or greater, install the radial hold back screws, only finger tight.
4. Place the two cartridge halves together. Install and tighten all four, coarse thread, joining bolts.
5. Tighten each of the side fixing screws, in a star pattern, until they are snug. Inspect the outer race joints, ensuring that they are flush. Remove the four joining bolts.

INSTRUCTION #6: Installing the Outer Race

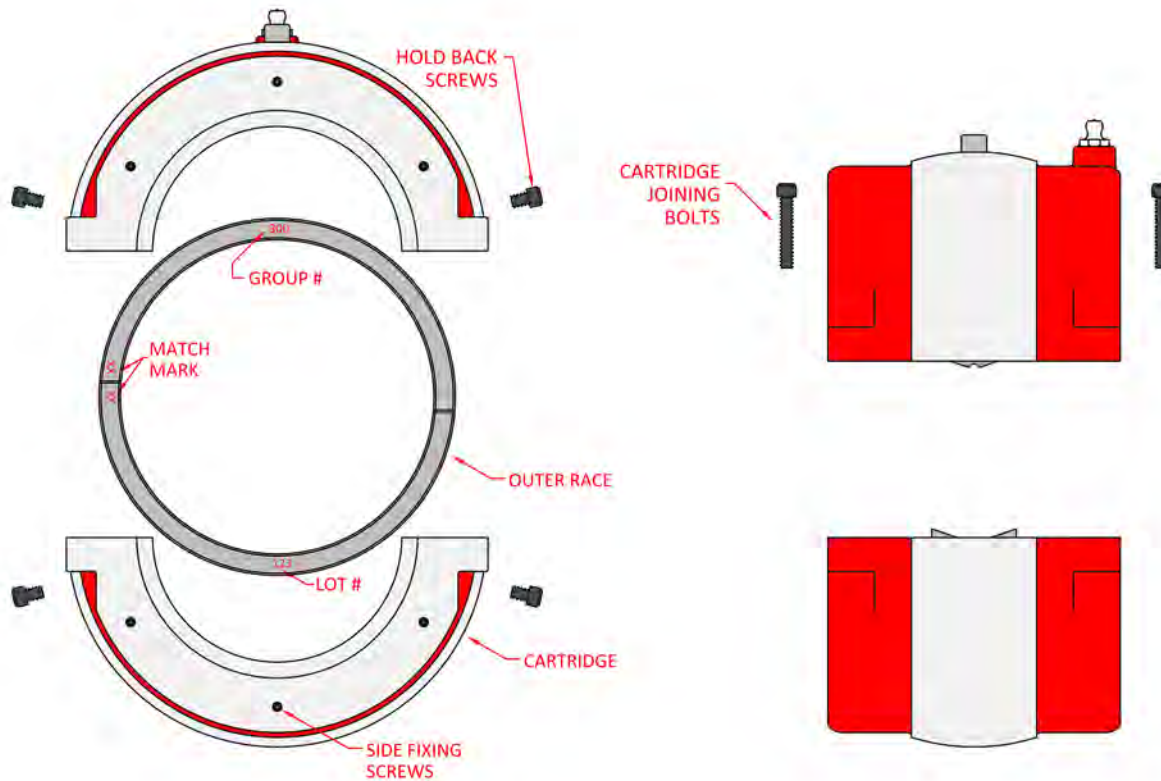

7 Installing the Cartridge

1. Apply grease (about 1/8" deep) to the interior of the cartridge bottom half. Grease the labyrinths of the cartridge. Slide the seals into position. Greasing the labyrinths serves to lubricate the seals and adds an additional grease barrier against contaminants.
2. Repeat the same procedure with the top half of the cartridge.
3. Place the cartridge halves together; install and tighten the cartridge joining bolts (course thread). Rotate cartridge in place to be sure it turns freely without binding. The anti-rotation pin in the top half of the cartridge mates into the housing cap.
4. Coat the spherical ball of the cartridge with a liberal amount of a quality moly or anti-seize compound. Be sure that the spherical ball is clean prior to lubricating. Do not use oil or grease for this purpose.

INSTRUCTION #7: Installing the Cartridge

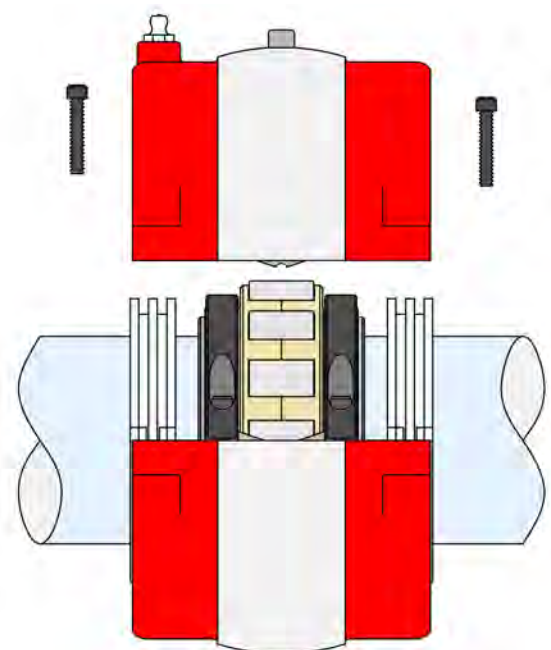

8 Installing the Pedestal Housing

1. Be sure the pedestal base mounting area is flat, clean, and free from burrs, nicks, etc.
2. If shimming of the pedestal housing base is necessary for adjusting base to center height, Craft recommends a full shim along the length and width of the housing base. **Pedestal base must be supported with 100% shim when required.**
3. Coat the pedestal housing base spherical area with an anti-seize compound. If not already in position, slide the base under the cartridge to its intended mounting position and loosely install the mounting bolts. With the anti-rotation pin on the cartridge properly located, slowly lower the shaft and allow the cartridge unit to settle in the base. When the bearing unit is properly positioned, tighten the mounting bolts.
4. Place the pedestal housing cap in position. Install the bolts, but do not fully tighten. After installation of all bearings, rotate the

shaft to allow the pillow blocks to align themselves with the shaft position. Tighten all cap bolts.

5. Perform a visual inspection. Be sure the bearings are properly lubricated, and all bolts are fully tightened before placing machinery in service.

With floating (FL) type bearings, be sure the cartridge and pedestal housing have not been moved in relationship to center with the inner race position on the shaft. A re-positioning of the inner race may be necessary if this has occurred. Simply take the down weight off the bearing, slightly loosen the clamp collar bolts without removing them, and tap the inner race up or down the shaft to re-center. When the race is back in center position, re-tighten the clamp collar bolts, and lower the shaft.

If heat related axial growth of the shaft is anticipated, the float (FL) inner race can be offset toward the anticipated heat source to accommodate this growth.

INSTRUCTION #8: Installing the Pedestal Housing

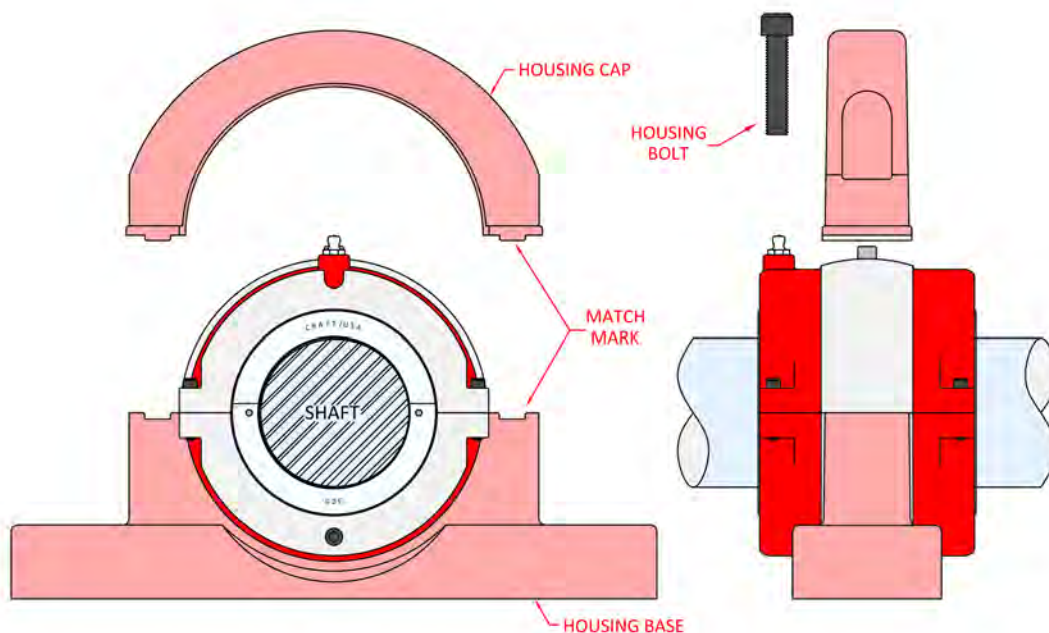

- 1** Check shaft for size and condition. Clean up if necessary.
- 2** Separate and pair up bearing components, remove all protective plastic, and wipe dry of protective oil coating before installation
- 3** Lubricate and install seals and move either side of bearing center position.
- 4** Install the inner race per instructions. Lubricate the raceway.
- 5** Lubricate and install roller cage assembly.
- 6** Lubricate grease path and install outer race in the cartridge.
- 7** Apply grease to seal labyrinths in the cartridge and outer race track, then install the cartridge.
- 8** Lubricate cartridge spherical outside diameter with anti-seize compound.
- 9** Install pedestal housing base. Lubricate housing spherical socket seat with anti-seize.
- 10** Make sure housing base is fully supported along its width and length.
- 11** Rotate the shaft and allow bearing(s) to align before final tightening of pedestal housing cap.
- 12** Perform a visual inspection of the installation, being sure all bolts are fully tightened before placing machinery in service.
- 13** Never install any rolling element bearing dry and lubricate after assembly. Always lubricate during assembly, before rotating the equipment under load.

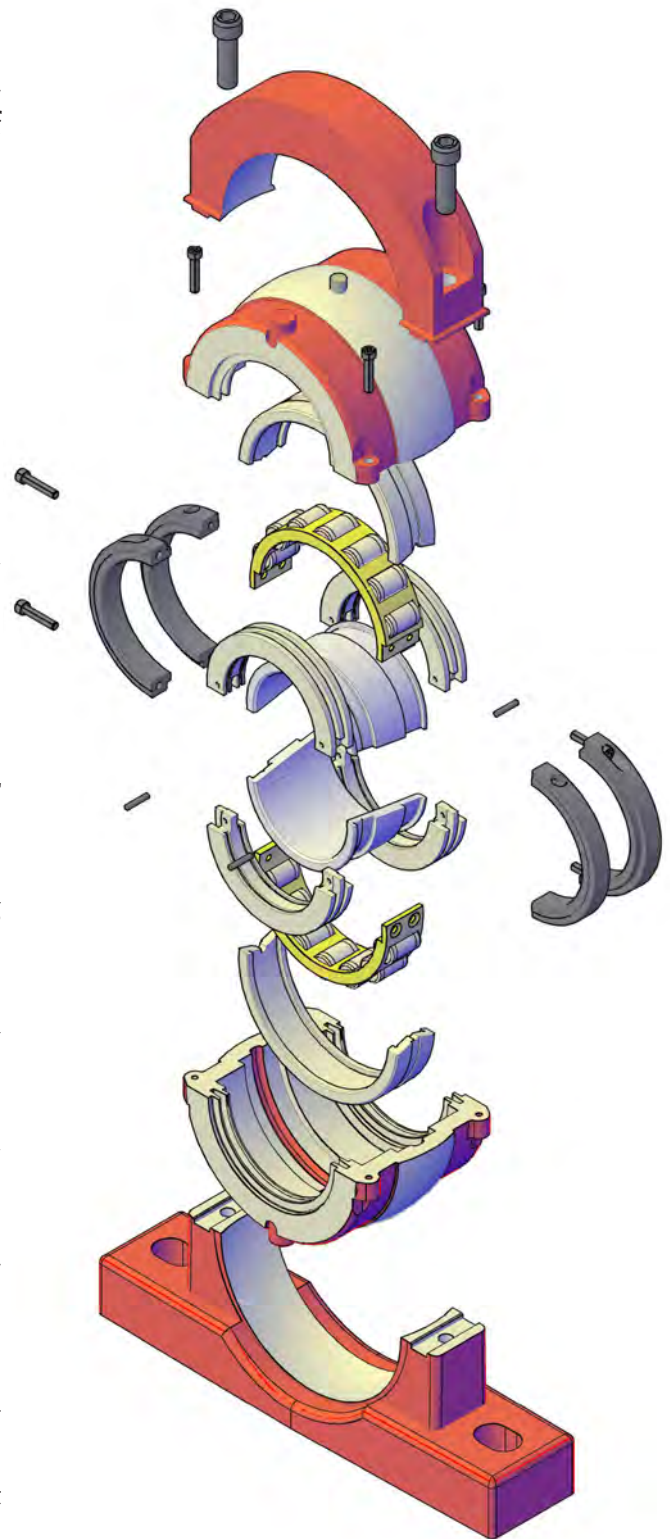

Series	Group	Clamp Collar			Cartridge			Pedestal Housing Cap			Flange Housing		
		Bolt	Key Size	Torque (ft-lbs)	Bolt	Key Size	Torque (ft-lbs)	Bolt	Key Size	Torque (ft-lbs)	Bolt	Key Size	Torque (ft-lbs)
S1	108	#10-32 UNF	5/32	3.1	#10-24 UNC	5/32	2.8	5/16-18 UNC	1/4	14			
S1	200	#10-32 UNF	5/32	3.1	#10-24 UNC	5/32	2.8	5/16-18 UNC	1/4	14	5/16-18 UNC	1/4	14
S1	208	#10-32 UNF	5/32	3.1	#10-24 UNC	5/32	2.8	3/8-16 UNC	5/16	24	3/8-16 UNC	5/16	24
S2		1/4-28 UNF	3/16	7.5	5/16-18 UNC	1/4	14	7/16-14 UNC	3/8	39	7/16-14 UNC	3/8	39
S1	300	#10-32 UNF	5/32	3.1	#10-24 UNC	5/32	2.8	7/16-14 UNC	3/8	39	7/16-14 UNC	3/8	39
S2		1/4-28 UNF	3/16	7.5	5/16-18 UNC	1/4	14	5/8-11 UNC	1/2	120	1/2-13 UNC	3/8	68
S1	308	1/4-28 UNF	3/16	7.5	1/4-20 UNC	3/16	6.6	5/8-11 UNC	1/2	120	1/2-13 UNC	3/8	68
S2		1/4-28 UNF	3/16	7.5	5/16-18 UNC	1/4	14	5/8-11 UNC	1/2	120	1/2-13 UNC	3/8	68
S1	400	1/4-28 UNF	3/16	7.5	1/4-20 UNC	3/16	6.6	5/8-11 UNC	1/2	120	1/2-13 UNC	3/8	68
S2		1/4-28 UNF	3/16	7.5	5/16-18 UNC	1/4	14	3/4-10 UNC	5/8	208	5/8-11 UNC	1/2	120
S1	408	1/4-28 UNF	3/16	7.5	1/4-20 UNC	3/16	6.6	3/4-10 UNC	5/8	208	5/8-11 UNC	1/2	120
S2		5/16-24 UNF	1/4	15	5/16-18 UNC	1/4	14	7/8-9 UNC	3/4	335	5/8-11 UNC	1/2	120
S1	500	1/4-28 UNF	3/16	7.5	1/4-20 UNC	3/16	6.6	7/8-9 UNC	3/4	386	5/8-11 UNC	1/2	120
S2		3/8-24 UNF	5/16	27	3/8-16 UNC	5/16	24	1-8 UNC	3/4	541	3/4-10 UNC	5/8	208
S1	508	5/16-24 UNF	1/4	15	5/16-18 UNC	1/4	14	7/8-9 UNC	3/4	386	5/8-11 UNC	1/2	120
S2		3/8-24 UNF	5/16	27	3/8-16 UNC	5/16	24	7/8-9 UNC	3/4	386	3/4-10 UNC	5/8	208
S1	600	5/16-24 UNF	1/4	15	5/16-18 UNC	1/4	14	1-8 UNC	3/4	541	3/4-10 UNC	5/8	208
S2		3/8-24 UNF	5/16	27	3/8-16 UNC	5/16	24	1-8 UNC	3/4	541	3/4-10 UNC	5/8	208
S3		3/8-24 UNF	5/16	27	3/8-16 UNC	5/16	24	3/4-10 UNC	5/8	208			
S1	608	3/8-24 UNF	5/16	27	3/8-16 UNC	5/16	24	3/4-10 UNC	5/8	208	3/4-10 UNC	5/8	208
S2		3/8-24 UNF	5/16	27	3/8-16 UNC	5/16	24	1-8 UNC	3/4	541	7/8-9 UNC	3/4	386
S3		1/2-20 UNF	3/8	66	1/2-13 UNC	3/8	59	3/4-10 UNC	5/8	208			
S1	700	3/8-24 UNF	5/16	27	3/8-16 UNC	5/16	24	7/8-9 UNC	3/4	386	3/4-10 UNC	5/8	208
S2		3/8-24 UNF	5/16	27	3/8-16 UNC	5/16	24	1-8 UNC	3/4	541	7/8-9 UNC	3/4	386
S3		1/2-20 UNF	3/8	66	1/2-13 UNC	3/8	59	1-8 UNC	3/4	541			

Note: If bolt is lubricated, reduce torque by 10%

Torque Specifications

Series	Group	Clamp Collar			Cartridge			Pedestal Housing Cap			Flange Housing		
		Bolt	Key Size	Torque (ft-lbs)	Bolt	Key Size	Torque (ft-lbs)	Bolt	Key Size	Torque (ft-lbs)	Bolt	Key Size	Torque (ft-lbs)
S1	800	3/8-24 UNF	5/16	27	3/8-16 UNC	5/16	24	7/8-9 UNC	3/4	386	7/8-9 UNC	3/4	386
S2		1/2-20 UNF	3/8	66	1/2-13 UNC	3/8	59	1-8 UNC	3/4	541	7/8-9 UNC	3/4	386
S3		1/2-20 UNF	3/8	66	1/2-13 UNC	3/8	59	1-8 UNC	3/4	541			
S1	900	3/8-24 UNF	5/16	27	3/8-16 UNC	5/16	24	7/8-9 UNC	3/4	386	7/8-9 UNC	3/4	386
S2		1/2-20 UNF	3/8	66	1/2-13 UNC	3/8	59	1-8 UNC	3/4	541	1-8 UNC	3/4	541
S3		5/8-18 UNF	1/2	133	5/8-11 UNC	1/2	120	1-8 UNC	3/4	541			
S1	1000	3/8-24 UNF	5/16	27	3/8-16 UNC	5/16	24	7/8-9 UNC	3/4	386	7/8-9 UNC	3/4	386
S2		1/2-20 UNF	3/8	66	1/2-13 UNC	3/8	59	1-8 UNC	3/4	541	1-8 UNC	3/4	541
S3		5/8-18 UNF	1/2	133	5/8-11 UNC	1/2	120	1-8 UNC	3/4	541			
S1	1100	7/16-20 UNF	3/8	43	1/2-13 UNC	3/8	59	1-8 UNC	3/4	541	1-8 UNC	3/4	541
S2		5/8-18 UNF	1/2	133	1/2-13 UNC	3/8	59	1 1/4-7 UNC	7/8	927	1-8 UNC	3/4	541
S3		7/8-14 UNF	3/4	369	5/8-11 UNC	1/2	120	1 1/4-7 UNC	7/8	927			
S1	1200	1/2-20 UNF	3/8	66	1/2-13 UNC	3/8	68	1-8 UNC	3/4	541	1-8 UNC	3/4	541
S2		5/8-18 UNF	1/2	133	1/2-13 UNC	3/8	63	1 1/4-7 UNC	7/8	927	1-8 UNC	3/4	541
S3		7/8-14 UNF	3/4	369	5/8-11 UNC	1/2	120	1 1/4-7 UNC	7/8	927			
S1	1300	3/8-24 UNF	5/16	27	1/2-13 UNC	3/8	59	1-8 UNC	3/4	541	1-8 UNC	3/4	541
S2		5/8-18 UNF	1/2	133	5/8-11 UNC	1/2	120	1 1/4-7 UNC	7/8	927	1-8 UNC	3/4	541
S3		7/8-14 UNF	3/4	369	5/8-11 UNC	1/2	120	1 1/4-7 UNC	7/8	927			
S1	1400	3/8-24 UNF	5/16	27	5/8-11 UNC	1/2	120	1-8 UNC	3/4	541	1-8 UNC	3/4	541
S2		5/8-18 UNF	1/2	133	5/8-11 UNC	1/2	120	1 1/4-7 UNC	7/8	927	1-8 UNC	3/4	541
S3		7/8-14 UNF	3/4	369	5/8-11 UNC	1/2	120	1 1/4-7 UNC	7/8	927			
S1	1500	7/16-20 UNF	3/8	43	5/8-11 UNC	1/2	120	1-8 UNC	3/4	541	1-8 UNC	3/4	541
S2		5/8-18 UNF	1/2	133	5/8-11 UNC	1/2	120	1 1/4-7 UNC	7/8	927	1-8 UNC	3/4	541
S3		7/8-14 UNF	3/4	369	5/8-11 UNC	1/2	120	1 1/4-7 UNC	7/8	927			
S1	1600	7/16-20 UNF	3/8	43	5/8-11 UNC	1/2	120	1-8 UNC	3/4	541	1-8 UNC	3/4	541
S2		5/8-18 UNF	1/2	133	5/8-11 UNC	1/2	120	1 1/4-7 UNC	7/8	927	1-8 UNC	3/4	541

Note: If bolt is lubricated, reduce torque by 10%

THE CRAFT SPLIT BEARING, as any mechanical part, will generate natural frequencies while in operation; also known as fundamental defect frequency. The natural frequencies are generated by the rolling of the rollers as they pass through the load zone. The four distinct natural frequencies generated are the ball spin frequency, fundamental train frequency, and ball pass frequency for the inner and outer race. By predicting the natural frequency of a bearing, design engineers can utilize the information to avoid natural excitation and monitor for the propagation of defects as part of a preventative maintenance program.

The ball spin frequency is the rate at which a point of the Craft bearing's roller comes into contact with either the inner or outer race. The fundamental train frequency is the frequency at which the roller cage entering and exits the load zone. The ball pass frequency is the rate at which a defect in the inner or outer race comes into contact with a roller. Below are the four equations for calculating the fundamental frequencies.

Ball Spin Frequency (Roller)

$$BSF = \left(\frac{D_p}{D_r}\right) \left(\frac{S}{2}\right) \times \left\{1 - \left(\frac{D_r}{D_p}\right)^2 \cos\phi\right\}$$

Fundamental Train Frequency (Cage)

$$FTF = \frac{S}{2} \times \left(1 - \frac{D_r}{D_p} \cos\phi\right)$$

Ball Pass Frequency Inner (Inner Race)

$$BPFI = N \times \left(\frac{S}{2}\right) \left(1 + \frac{D_r}{D_p} \cos\phi\right)$$

Ball Pass Frequency Outer (Outer Race)

$$BPFO = N \times \left(\frac{S}{2}\right) \left(1 - \frac{D_r}{D_p} \cos\phi\right)$$

Where,

S = Shaft Speed in RPMs

D_r = Roller Diameter in inches

D_p = Pitch diameter in inches

N = Number of rollers

ϕ = Contact angle = 0

Size	Series	Pitch Dia.	Roller Dia.	# of Rollers	Frequency Per Shaft Revolution			
					Cage	Roller	Inner Race	Outer Race
108	S1	2.468	0.469	10	0.405	2.537	5.950	4.050
200	S1	3.000	0.500	12	0.417	2.917	7.000	5.000
208	S1	3.560	0.563	12	0.421	3.085	6.948	5.052
	S2	3.875	0.688	12	0.411	2.729	7.065	4.935
300	S1	4.190	0.625	14	0.425	3.277	8.044	5.956
	S2	4.563	0.813	12	0.411	2.719	7.068	4.932
308	S1	4.874	0.688	14	0.429	3.474	7.987	6.013
	S2	5.250	0.875	14	0.417	2.917	8.167	5.833
400	S1	5.563	0.813	14	0.427	3.348	8.023	5.977
	S2	6.000	1.000	14	0.417	2.917	8.167	5.833
408	S1	6.252	0.875	16	0.430	3.503	9.120	6.880
	S2	6.750	1.125	14	0.417	2.917	8.167	5.833
500	S1	6.875	0.938	16	0.432	3.598	9.091	6.909
	S2	7.500	1.250	14	0.417	2.917	8.167	5.833

Bearing Frequency Data

Size	Series	Pitch Dia.	Roller Dia.	# of Rollers	Frequency Per Shaft Revolution			
					Cage	Roller	Inner Race	Outer Race
508	S1	7.500	1.000	16	0.433	3.683	9.067	6.933
	S2	8.125	1.375	14	0.415	2.870	8.185	5.815
600	S1	8.000	1.000	18	0.438	3.938	10.125	7.875
	S2	8.750	1.375	16	0.421	3.103	9.257	6.743
	S3	9.500	2.000	12	0.395	2.270	7.263	4.737
608	S1	8.625	1.063	18	0.438	3.995	10.109	7.891
	S2	9.500	1.500	14	0.421	3.088	8.105	5.895
	S3	10.250	1.875	14	0.409	2.642	8.280	5.720
700	S1	9.125	1.063	20	0.442	4.234	11.165	8.835
	S2	10.000	1.500	16	0.425	3.258	9.200	6.800
	S3	10.889	1.938	14	0.411	2.720	8.246	5.754
800	S1	10.126	1.063	22	0.448	4.713	12.154	9.846
	S2	11.250	1.625	16	0.428	3.389	9.156	6.844
	S3	12.110	2.188	14	0.410	2.678	8.264	5.736
900	S1	11.250	1.125	22	0.450	4.950	12.100	9.900
	S2	12.250	1.625	18	0.434	3.703	10.194	7.806
	S3	13.750	2.375	12	0.414	2.808	7.036	4.964
1000	S1	12.376	1.125	26	0.455	5.455	14.182	11.818
	S2	13.505	1.750	18	0.435	3.794	10.166	7.834
	S3	14.500	2.375	14	0.418	2.971	8.147	5.853
1100	S1	13.500	1.250	24	0.454	5.354	13.111	10.889
	S2	14.625	1.875	18	0.436	3.836	10.154	7.846
	S3	15.372	2.375	16	0.423	3.159	9.236	6.764
1200	S1	14.625	1.250	24	0.457	5.807	13.026	10.974
	S2	15.750	1.875	20	0.440	4.140	11.190	8.810
	S3	17.006	2.500	16	0.461	3.328	9.176	6.824
1300	S1	15.620	1.313	26	0.458	5.908	14.092	11.908
	S2	17.020	1.875	20	0.445	4.484	11.102	8.898
	S3	18.741	2.875	14	0.423	3.183	8.074	5.926
1400	S1	16.620	1.313	26	0.461	6.292	14.027	11.973
	S2	18.120	2.063	20	0.443	4.336	11.138	8.862
	S3	19.113	2.750	16	0.428	3.403	9.151	6.849
1500	S1	17.745	1.375	28	0.461	6.414	15.085	12.915
	S2	19.000	2.063	22	0.446	4.552	12.194	9.806
	S3	21.000	3.000	16	0.429	3.429	9.143	6.857
1600	S1	18.745	1.375	30	0.463	6.780	16.100	13.900
	S2	20.125	2.188	22	0.446	4.546	12.196	9.804

Mounted Unit

BEARING DIMENSIONS

Shaft Diameter	Complete* Component	Pedestal Housing	A**	B	C‡	D	E		F	H	Bolts	Weight lbs.
							Minimum	Maximum				
1 7/16 1 1/2 35 mm 40 mm	S1 BCH 107 S1 BCH 108 S1 BCH 35mm S1 BCH 40mm	PH 1	2 3/8	9	2 3/8	8-Jul	6 3/4	7 1/2	-	5 1/2	Two 1/2	11.05
1 11/16 1 3/4 1 15/16 2 45 mm 50 mm	S1 BCH 111 S1 BCH 112 S1 BCH 115 S1 BCH 200 S1 BCH 45mm S1 BCH 50mm	PH 2	2 3/4	10 5/8	2 3/8	1	8	8 7/8	-	6 1/4	Two 5/8	18.5
2 3/16 2 1/4 2 7/16 2 1/2 55 mm 60 mm 65 mm	S1 BCH 203 S1 BCH 204 S1 BCH 207 S1 BCH 208 S1 BCH 55mm S1 BCH 60mm S1 BCH 65mm	PH 3	3 5/32	11	2 3/4	1 1/4	8 7/8	9 1/2	-	7	Two 3/4	25.4
2 11/16 2 3/4 2 15/16 3 70 mm 75 mm	S1 BCH 211 S1 BCH 212 S1 BCH 215 S1 BCH 300 S1 BCH 70mm S1 BCH 75mm	PH 4	3 3/4	13	3	1 1/2	10 1/4	11	-	7 7/8	Two 3/4	33
3 3/16 3 1/4 3 7/16 3 1/2 80 mm 85 mm 90 mm	S1 BCH 303 S1 BCH 304 S1 BCH 307 S1 BCH 308 S1 BCH 80mm S1 BCH 85mm S1 BCH 90mm	PH 5 2B PH 5 4B	4 13/32	15	3 1/2 5 1/2	1 3/4	12 3/16 12 3/8	13 3/16 13 3/8	- 3 1/2	10 1/16	Two 3/4 Four 3/4	58 64.3
3 11/16 3 3/4 3 15/16 4 100 mm 105 mm	S1 BCH 311 S1 BCH 312 S1 BCH 315 S1 BCH 400 S1 BCH 100mm S1 BCH 105mm	PH 6 2B PH 6 4B	4 15/16	16 3/4	4 1/4 6	2	13 1/2 14	14 7/8 15	- 4	10 3/4	Two 3/4 Four 3/4	75.2 83.6
4 3/16 4 1/4 4 7/16 4 1/2 110 mm 115 mm	S1 BCH 403 S1 BCH 404 S1 BCH 407 S1 BCH 408 S1 BCH 110mm S1 BCH 115mm	PH 7	5 5/8	18 3/4	6 3/4	2 3/8	15 3/4	16 11/16	4 1/2	12 3/8	Four 3/4	110
4 11/16 4 3/4 4 15/16 5 120 mm 125 mm 130 mm	S1 BCH 411 S1 BCH 412 S1 BCH 415 S1 BCH 500 S1 BCH 120mm S1 BCH 125mm S1 BCH 130mm	PH 8	6 3/8	20	7	1 1/2	17 1/4	18 3/16	4 3/4	14	Four 7/8	175.9
5 3/16 5 1/4 5 7/16 5 1/2 135 mm 140 mm	S1 BCH 503 S1 BCH 504 S1 BCH 507 S1 BCH 508 S1 BCH 135mm S1 BCH 140mm	PH 9	7 1/8	22	7	1 9/16	18 1/2	19 1/2	4 3/4	15 1/2	Four 7/8	201.4
5 15/16 6 150 mm 155 mm 160 mm	S1 BCH 515 S1 BCH 600 S1 BCH 150mm S1 BCH 155mm S1 BCH 160mm	PH 10	7 1/8	22	7	1 5/8	18 1/2	20 1/2	4 3/4	15 3/4	Four 7/8	224.5

* Specify Suffix – FL for float bearing, HD for held bearing
** Base to center height can be altered upon request

Special application bearings are available upon request.
‡ Housing width only

Dimensions in inches
Normal operating temperature for standard bearings is 32°F to 212°F

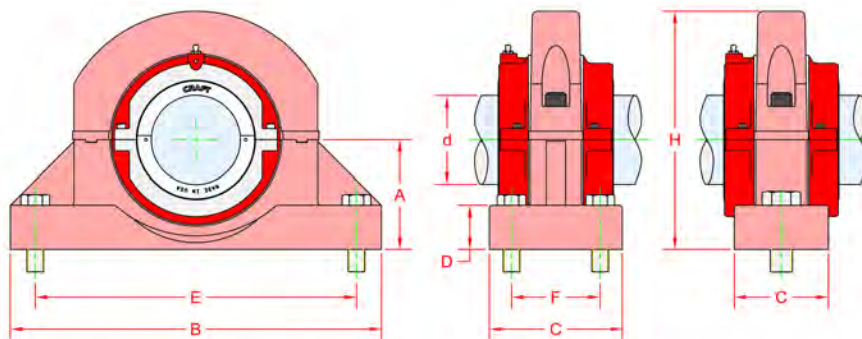

Cartridge Assembly

Shaft Diameter	Cartridge* Assembly	Cartridge	L	G‡	Weight lbs.	Grease Capacity
1 7/16 1 1/2 35 mm 40 mm	S1 BC 107 S1 BC 108 S1 BC 35mm S1 BC 40mm	S1 C 108	3 15/16	3 5/16	6.9	2.0 oz
1 11/16 1 3/4 1 15/16 2 45 mm 50 mm	S1 BC 111 S1 BC 112 S1 BC 115 S1 BC 200 S1 BC 45mm S1 BC 50mm	S1 C 200	4 5/8	3 3/4	9.2	3.2 oz
2 3/16 2 1/4 2 7/16 2 1/2 55 mm 60 mm 65 mm	S1 BC 203 S1 BC 204 S1 BC 207 S1 BC 208 S1 BC 55mm S1 BC 60mm S1 BC 65mm	S1 C 208	5 5/16	4	11.6	5.2 oz
2 11/16 2 3/4 2 15/16 3 70 mm 75 mm	S1 BC 211 S1 BC 212 S1 BC 215 S1 BC 300 S1 BC 70mm S1 BC 75mm	S1 C 300	6 3/16	4 3/8	18.5	6.2 oz
3 3/16 3 1/4 3 7/16 3 1/2 80 mm 85 mm 90 mm	S1 BC 303 S1 BC 304 S1 BC 307 S1 BC 308 S1 BC 80mm S1 BC 85mm S1 BC 90mm	S1 C 308	7	5 3/16	25.5	10.5 oz
3 11/16 3 3/4 3 15/16 4 100 mm 105 mm	S1 BC 311 S1 BC 312 S1 BC 315 S1 BC 400 S1 BC 100mm S1 BC 105mm	S1 C 400	8	5 3/16	32.3	12.5 oz
4 3/16 4 1/4 4 7/16 4 1/2 110 mm 115 mm	S1 BC 403 S1 BC 404 S1 BC 407 S1 BC 408 S1 BC 110mm S1 BC 115mm	S1 C 408	9 1/8	5 9/16	48.6	1.2 lbs
4 11/16 4 3/4 4 15/16 5 120 mm 125 mm 130 mm	S1 BC 411 S1 BC 412 S1 BC 415 S1 BC 500 S1 BC 120mm S1 BC 125mm S1 BC 130mm	S1 C 500	10 1/2	6 1/16	71.7	1.4 lbs
5 3/16 5 1/4 5 7/16 5 1/2 135 mm 140 mm	S1 BC 503 S1 BC 504 S1 BC 507 S1 BC 508 S1 BC 135mm S1 BC 140mm	S1 C 508	11	6 9/16	81.1	1.8 lbs
5 15/16 6 150 mm 155 mm 160 mm	S1 BC 515 S1 BC 600 S1 BC 150mm S1 BC 155mm S1 BC 160mm	S1 C 600	11 5/8	6 3/4	97	2.0 lbs

* Specify Suffix – FL for float bearing,
HD for held bearing
** Based on Axial Capacity at 1000 RPM.

‡ Length through bore.

Dimensions in inches

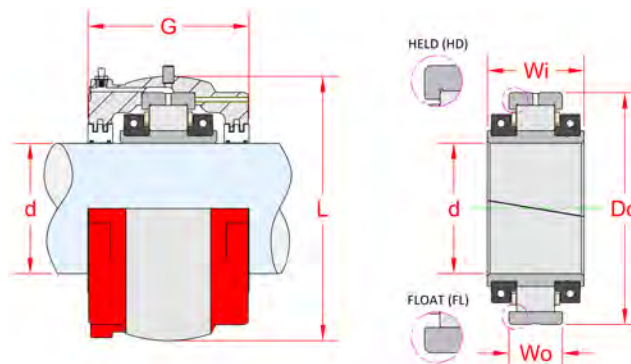

Roller Bearing

Bearing*	Bearing Rating lbs.			Max RPM	Do	Wi	Wo	Weight lbs.
	Dynamic Cr	Static Co	Axial Ca**					
S1 B 107 S1 B 108 S1 B 35mm S1 B 40mm	13870	15560	285	5420	3.313	1.972	0.938	2.3
S1 B 111 S1 B 112 S1 B 115 S1 B 200 S1 B 45mm S1 B 50mm	18291	22496	326	4456	3.875	2.192	1.000	3.5
S1 B 203 S1 B 204 S1 B 207 S1 B 208 S1 B 55mm S1 B 60mm S1 B 65mm	20255	24851	351	3750	4.5	2.192	1.063	3.5
S1 B 211 S1 B 212 S1 B 215 S1 B 300 S1 B 70mm S1 B 75mm	29843	40077	433	3190	5.25	2.41	1.25	6
S1 B 303 S1 B 304 S1 B 307 S1 B 308 S1 B 80mm S1 B 85mm S1 B 90mm	37552	52749	453	2740	6	2.781	1.531	9.2
S1 B 311 S1 B 312 S1 B 315 S1 B 400 S1 B 100mm S1 B 105mm	51215	73061	552	2400	6.875	3.188	1.781	13.9
S1 B 403 S1 B 404 S1 B 407 S1 B 408 S1 B 110mm S1 B 115mm	63207	94628	654	2140	8	3.342	1.844	20.8
S1 B 411 S1 B 412 S1 B 415 S1 B 500 S1 B 120mm S1 B 125mm S1 B 130mm	72821	111390	685	1940	8.75	3.531	2.125	25.5
S1 B 503 S1 B 504 S1 B 507 S1 B 508 S1 B 135mm S1 B 140mm	80703	124806	717	1780	9.5	3.875	2.188	32.4
S1 B 515 S1 B 600 S1 B 150mm S1 B 155mm S1 B 160mm	87598	141757	762	1670	10	3.875	2.188	37.1

Mounted Unit

BEARING DIMENSIONS

Shaft Diameter	Complete* Component	Pedestal Housing	A**	B	C‡	D	E		F	H	Bolts	Weight lbs.
							Minimum	Maximum				
6 7/16 6 1/2 160 mm 165 mm	S1 BCH 607 S1 BCH 608 S1 BCH 160mm S1 BCH 165mm	PH 11	8 3/8	20	7	1 1/4	14	15	4 1/2	17	Four 1	236
6 11/16 6 15/16 7 170 mm 180 mm	S1 BCH 611 S1 BCH 615 S1 BCH 700 S1 BCH 170mm S1 BCH 180mm	PH 12	9 1/4	21	7 1/2	1 3/8	14 3/8	15 3/4	5	18 1/2	Four 1	283
7 1/2 7 15/16 8 190 mm 200 mm	S1 BCH 708 S1 BCH 715 S1 BCH 800 S1 BCH 190mm S1 BCH 200mm	PH 13	9 3/4	22 1/2	8	1 1/2	16 1/8	17 1/8	5 1/2	19 1/2	Four 1	321
8 1/2 8 15/16 9 220 mm	S1 BCH 808 S1 BCH 815 S1 BCH 900 S1 BCH 220mm	PH 14	10 5/8	25	8 1/2	1 5/8	17 3/8	18 7/8	5 1/2	21 1/4	Four 1 1/4	372
9 1/2 9 15/16 10 240 mm 250 mm	S1 BCH 908 S1 BCH 915 S1 BCH 1000 S1 BCH 240mm S1 BCH 250mm	PH 15	11 1/2	27	9	1 3/4	19	20 1/2	5 1/2	23	Four 1 1/4	512
10 1/2 10 15/16 11 260 mm 280 mm	S1 BCH 1008 S1 BCH 1015 S1 BCH 1100 S1 BCH 260mm S1 BCH 280mm	PH 16	12 1/4	28 1/2	9	1 7/8	20 1/4	21 3/4	5 1/2	24 1/2	Four 1 1/4	605
11 1/2 11 15/16 12 300 mm	S1 BCH 1108 S1 BCH 1115 S1 BCH 1200 S1 BCH 300mm	PH 17	13 1/2	30	10	2	22 1/4	23 3/4	7	26 3/4	Four 1 1/4	742
12 1/2 13 320 mm	S1 BCH 1208 S1 BCH 1300 S1 BCH 320mm	PH 18	14 1/2	32	10	2 1/8	23 3/4	25 1/4	7	29	Four 1 1/2	920
14 340 mm	S1 BCH 1400 S1 BCH 340mm	PH 19	15 1/4	33 1/2	10	2 1/4	25	26 1/2	6 1/2	30 1/2	Four 1 1/2	1,100
15 360 mm 380 mm	S1 BCH 1500 S1 BCH 360mm S1 BCH 380mm	PH 20	15 5/8	35 1/2	10	2 3/8	25 7/8	27 3/8	6 1/2	30 1/4	Four 1 1/2	1,150
15 3/4 16 400 mm	S1 BCH 1512 S1 BCH 1600 S1 BCH 400mm	PH 116	17	37	10	2 5/8	27 11/16	29 5/16	6 9/16	34 1/16	Four 1 1/2	1,200

* Specify Suffix – FL for float bearing,
HD for held bearing

** Base to center height can be altered upon request

Special application bearings are available upon request.

‡ Housing width only

Dimensions in inches
Normal operating temperature for
standard bearings is 32°F to 212°F

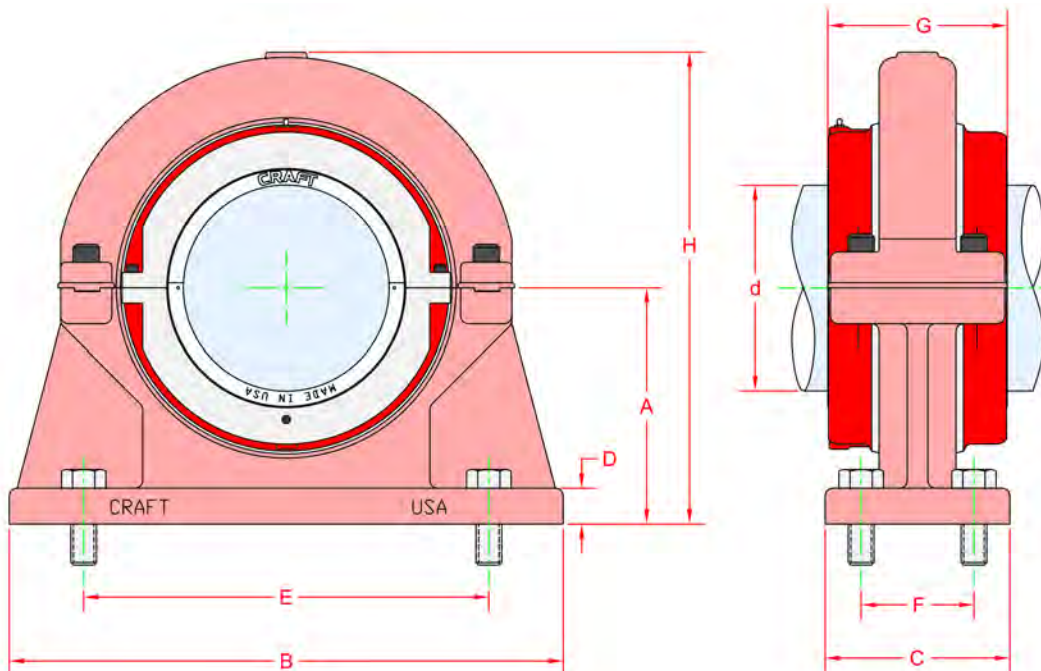

Cartridge Assembly

Shaft Diameter	Cartridge* Assembly	Cartridge	L	G‡	Weight lbs.	Grease Capacity
6 7/16 6 1/2 160 mm 165 mm	S1 BC 607 S1 BC 608 S1 BC 160mm S1 BC 165mm	S1 C 608	12 1/4	7 9/16	110	2.1 lbs
6 11/16 6 15/16 7 170 mm 180 mm	S1 BC 611 S1 BC 615 S1 BC 700 S1 BC 170mm S1 BC 180mm	S1 C 700	12 3/4	7 7/8	137	2.4 lbs
7 1/2 7 15/16 8 190 mm 200 mm	S1 BC 708 S1 BC 715 S1 BC 800 S1 BC 190mm S1 BC 200mm	S1 C 800	14 1/8	7 7/8	151	3.2 lbs
8 1/2 8 15/16 9 220 mm	S1 BC 808 S1 BC 815 S1 BC 900 S1 BC 220mm	S1 C 900	15 1/4	8 1/2	174	3.3 lbs
9 1/2 9 15/16 10 240 mm 250 mm	S1 BC 908 S1 BC 915 S1 BC 1000 S1 BC 240mm S1 BC 250mm	S1 C 1000	16 1/2	8 3/4	227	4.2 lbs
10 1/2 10 15/16 11 260 mm 280 mm	S1 BC 1008 S1 BC 1015 S1 BC 1100 S1 BC 260mm S1 BC 280mm	S1 C 1100	17 7/8	9 1/8	279	4.2 lbs
11 1/2 11 15/16 12 300 mm	S1 BC 1108 S1 BC 1115 S1 BC 1200 S1 BC 300mm	S1 C 1200	19 1/4	9 3/4	378	4.4 lbs
12 1/2 13 320 mm	S1 BC 1208 S1 BC 1300 S1 BC 320mm	S1 C 1300	20 3/4	11 3/4	441	6.0 lbs
14 340 mm	S1 BC 1400 S1 BC 340mm	S1 C 1400	21 1/2	10 1/2	376	6.7 lbs
15 360 mm 380 mm	S1 BC 1500 S1 BC 360mm S1 BC 380mm	S1 C 1500	22 1/2	11	486	7 lbs
15 3/4 16 400 mm	S1 BC 1512 S1 BC 1600 S1 BC 400mm	S1 C 1600	23 3/4	11 1/8	578	8 lbs

* Specify Suffix – FL for float bearing,
HD for held bearing
** Based on Axial Capacity at 100 RPM.

‡ Length through bore.

Dimensions in inches

Roller Bearing

Bearing*	Bearing Rating lbs.			Max RPM	Do	Wi	Wo	Weight lbs.
	Dynamic Cr	Static Co	Axial Ca**					
S1 B 607 S1 B 608 S1 B 160mm S1 B 165mm	97258	159049	7993	1550	10.75	4.291	2.375	47
S1 B 611 S1 B 615 S1 B 700 S1 B 170mm S1 B 180mm	104510	178085	8445	1465	11.25	4.291	2.185	46
S1 B 708 S1 B 715 S1 B 800 S1 B 190mm S1 B 200mm	110607	198444	8459	1320	12.25	4.291	2.375	50
S1 B 808 S1 B 815 S1 B 900 S1 B 220mm	121869	223077	8566	1190	13.5	4.528	2.5	63
S1 B 908 S1 B 915 S1 B 1000 S1 B 240mm S1 B 250mm	136054	266300	9280	1080	14.75	4.803	2.625	82
S1 B 1008 S1 B 1015 S1 B 1100 S1 B 260mm S1 B 280mm	156486	303690	9679	990	16	5.039	2.719	100
S1 B 1108 S1 B 1115 S1 B 1200 S1 B 300mm	163906	331580	9743	915	17.25	5.625	2.938	123
S1 B 1208 S1 B 1300 S1 B 320mm	177820	363370	10072	856	18.26	5.352	2.937	126
S1 B 1400 S1 B 340mm	176733	367612	9510	805	19.25	5.352	2.937	139
S1 B 1500 S1 B 360mm S1 B 380mm	203501	436765	10540	753	20.5	5.509	3	151
S1 B 1512 S1 B 1600 S1 B 400mm	204980	449532	10733	713	21.5	5.509	3	160

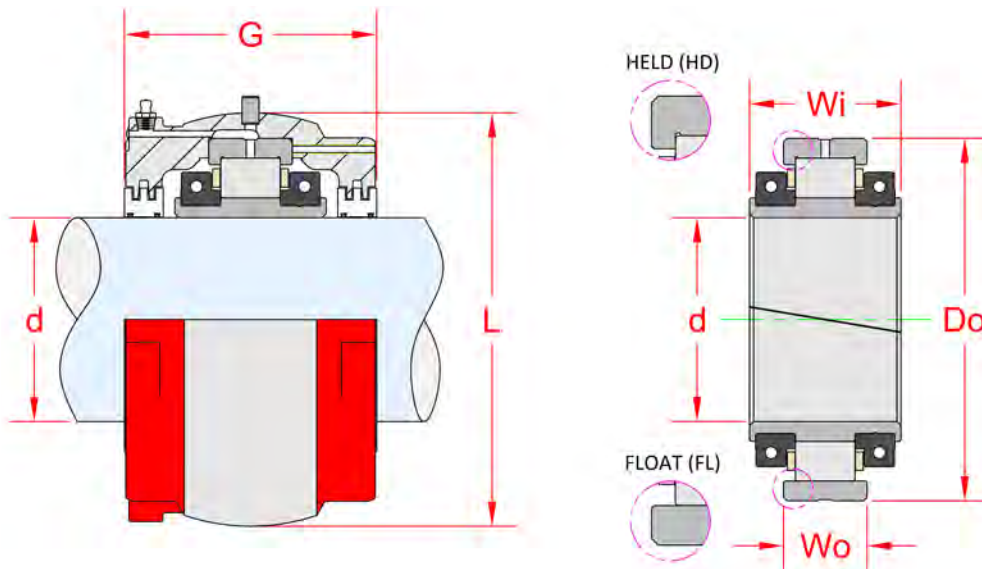

Flange Unit

BEARING DIMENSIONS

Shaft Diameter	Complete* Component	Flange Housing	Y	K	X	Z	S	T	P	Bolts	Weight lbs.
2 3/16 2 1/4 2 7/16 2 1/2 55 mm 60 mm 65 mm	S1 BCF 203 S1 BCF 204 S1 BCF 207 S1 BCF 208 S1 BCF 55mm S1 BCF 60mm S1 BCF 65mm	FH 3	10 1/4	4 11/16	2 5/8	8 9/16	6 1/16	5/8	6 9/16	Four 1/2	37
2 11/16 2 3/4 2 15/16 3 70 mm 75 mm	S1 BCF 211 S1 BCF 212 S1 BCF 215 S1 BCF 300 S1 BCF 70mm S1 BCF 75mm	FH 4	11 1/4	5 1/8	2 7/8	9 9/16	6 3/4	5/8	7 9/16	Four 1/2	53
3 3/16 3 1/4 3 7/16 3 1/2 80 mm 85 mm 90 mm	S1 BCF 303 S1 BCF 304 S1 BCF 307 S1 BCF 308 S1 BCF 80mm S1 BCF 85mm S1 BCF 90mm	FH 5	13	5 13/16	3 1/8	10 3/4	7 5/8	3/4	8 1/2	Four 1/2	80
3 11/16 3 3/4 3 15/16 4 100 mm 105 mm	S1 BCF 311 S1 BCF 312 S1 BCF 315 S1 BCF 400 S1 BCF 100mm S1 BCF 105 mm	FH 6	14	6	3 3/8	11 7/8	8 3/8	3/4	9 5/8	Four 5/8	94
4 3/16 4 1/4 4 7/16 4 1/2 110 mm 115 mm	S1 BCF 403 S1 BCF 404 S1 BCF 407 S1 BCF 408 S1 BCF 110mm S1 BCF 115mm	FH 7	15	6 7/16	3 5/8	13 1/8	9 1/4	7/8	10 7/8	Four 5/8	122
4 11/16 4 3/4 4 15/16 5 120 mm 125 mm 130 mm	S1 BCF 411 S1 BCF 412 S1 BCF 415 S1 BCF 500 S1 BCF 120mm S1 BCF 125mm S1 BCF 130mm	FH 8	17	6 15/16	3 7/8	15 1/8	10 11/16	1	12 1/2	Four 7/8	165
5 3/16 5 1/4 5 7/16 5 1/2 135 mm 140 mm	S1 BCF 503 S1 BCF 504 S1 BCF 507 S1 BCF 508 S1 BCF 135mm S1 BCF 140mm	FH 9	17 1/2	7 1/8	3 7/8	15 1/8	10 11/16	1	12 1/2	Four 7/8	181
5 15/16 6 150 mm 155 mm 160 mm	S1 BCF 515 S1 BCF 600 S1 BCF 150mm S1 BCF 155mm S1 BCF 160mm	FH 10	18 1/2	7 15/16	4 1/2	16 1/4	11 1/2	1	13 5/8	Four 1	215

*Specify Suffix – FL for float bearing,
HD for held bearing
Special application bearings are available upon request.

Dimensions in inches
Normal operating temperature for
standard bearings is 32°F to 212°F

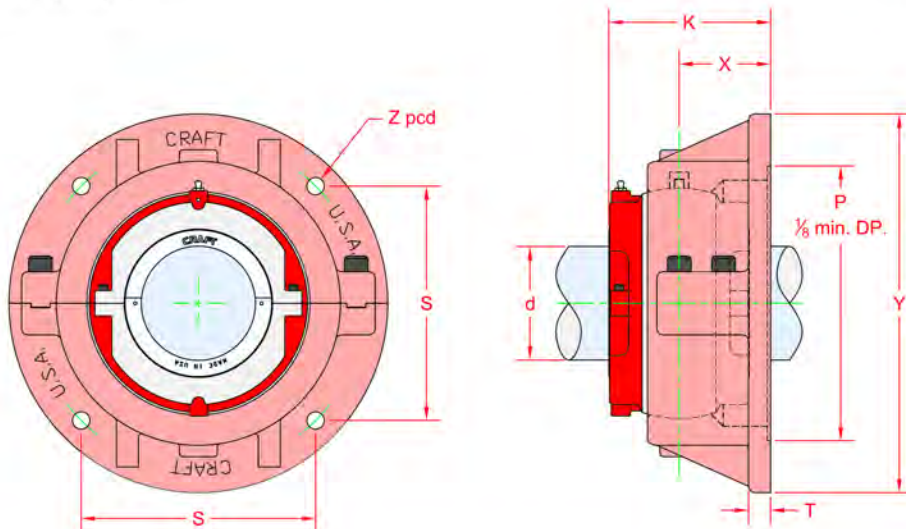

S1 Series Large Bore Flange Block

Flange Unit

BEARING DIMENSIONS

Shaft Diameter	Complete* Component	Flange Housing	Y	K	X	Z	S	T	P	Bolts	Weight lbs.
6 7/16 6 1/2 160 mm 165 mm	S1 BCF 607 S1 BCF 608 S1 BCF 160mm S1 BCF165mm	FH 11	19 1/2	7 15/16	4 1/8	16 3/4	11 7/8	1	13 7/8	Four 1	242
6 15/16 7 170 mm 180 mm	S1 BCF 615 S1 BCF 700 S1 BCF 170mm S1 BCF 180mm	FH 12	20	8 3/16	4 1/4	17 1/4	12 3/16	1 1/8	14 3/8	Four 1	265
7 1/2 7 15/16 8 190 mm 200 mm	S1 BCF 708 S1 BCF 715 S1 BCF 800 S1 BCF 190mm S1 BCF 200mm	FH 13	21	8 3/16	4 1/4	18 5/8	13 3/16	1 1/4	15 3/4	Four 1	306
8 1/2 8 15/16 9 220 mm	S1 BCF 808 S1 BCF 815 S1 BCF 900 S1 BCF 220mm	FH 14	23	8 7/8	4 5/8	20 1/8	14 1/4	1 3/8	17	Four 1 1/4	365
9 1/2 9 15/16 10 240 mm 250 mm	S1 BCF 908 S1 BCF 915 S1 BCF 1000 S1 BCF 240mm S1 BCF 250mm	FH 15	24	9	4 5/8	21 3/8	15 1/16	1 3/8	18 1/4	Four 1 1/4	407
10 1/2 11 270 mm 280 mm	S1 BCF 1008 S1 BCF 1100 S1 BCF 270mm S1 BCF 280mm	FH 16	26	9 7/16	4 7/8	23	16 1/4	1 1/2	19 7/8	Four 1 1/4	521
11 1/2 12 290 mm 300 mm	S1 BCF 1108 S1 BCF 1200 S1 BCF 290mm S1 BCF 300mm	FH 17	28	10 1/8	5 1/4	24 5/8	17 7/16	1 1/2	21 1/4	Four 1 1/4	642
12 1/2 13 320 mm	S1 BCF 1208 S1 BCF 1300 S1 BCF 320mm	FH 18	32	11 3/8	6	27 1/2	19 7/16	1 1/2	23	Four 1 1/2	840
14 340 mm	S1 BCF 1400 S1 BCF 340mm	FH 19	33 1/2	10 7/8	5 1/2	29	20 1/2	1 5/8	24	Four 1 1/2	820
15 360 mm 380 mm	S1 BCF 1500 S1 BCF 360mm S1 BCF 380mm	FH 115	36	12	6 1/2	31 1/2	22 9/32	1 3/4	26 1/2	Eight 1 1/4	1090
16 400 mm	S1 BCF 1600 S1 BCF 400mm	FH 116	36	12 1/8	6 1/2	31 1/2	22 9/32	1 3/4	26 1/2	Eight 1 1/4	1110

*Specify Suffix – FL for float bearing,
HD for held bearing
Special application bearings are available upon request.

Dimensions in inches
Normal operating temperature for
standard bearings is 32°F to 212°F

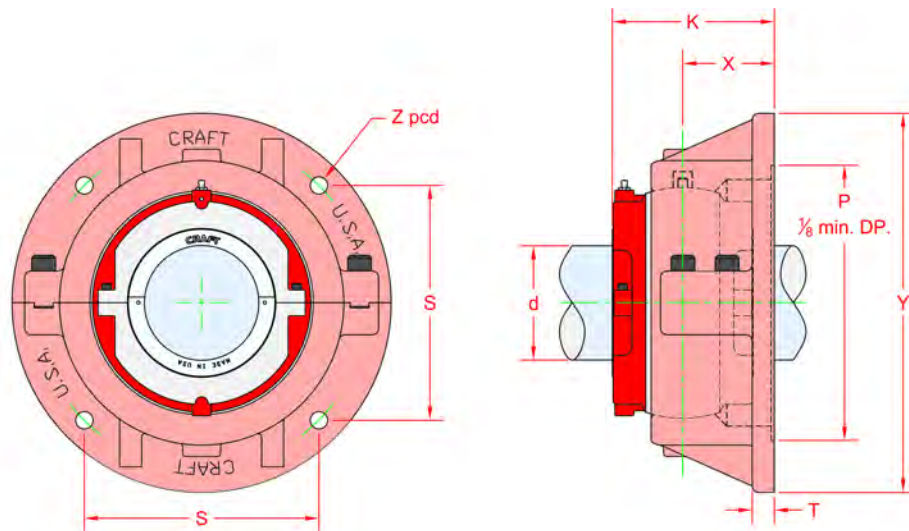

Mounted Unit

BEARING DIMENSIONS

Shaft Diameter	Complete* Component	Pedestal Housing	A**	B	C‡	D	E	F	H	Bolts	Weight lbs.
3 11/16 3 3/4 3 15/16 4 100 mm 105 mm	S1 SNLH 311 S1 SNLH 312 S1 SNLH 315 S1 SNLH 400 S1 SNLH 100mm S1 SNLH 105mm	SNLH 6	4 15/16 [125 mm]	16 1/8	2 5/16	1 9/16	13 3/4	—	10 3/4	Two 1	84
4 3/16 4 1/4 4 7/16 4 1/2 110 mm 115 mm	S1 SNLH 403 S1 SNLH 404 S1 SNLH 407 S1 SNLH 408 S1 SNLH 110mm S1 SNLH 115mm	SNLH 7	5 1/2 [140 mm]	16 1/8	2 7/8	1 9/16	13 7/8	—	12 1/4	Two 1	110
4 3/16 4 1/4 4 7/16 4 1/2 110 mm 115 mm	S1 SSNH 403 S1 SSNH 404 S1 SSNH 407 S1 SSNH 408 S1 SSNH 110mm S1 SSNH 115mm	SSNH 7	4 7/8 [124 mm]	14 7/8	5 5/8	1 3/8	12 3/4	3 1/2	11 5/8	Four 1	110
4 11/16 4 3/4 4 15/16 5 120 mm 125 mm 130 mm	S1 SNLH 411 S1 SNLH 412 S1 SNLH 415 S1 SNLH 500 S1 SNLH 120mm S1 SNLH 125mm S1 SNLH 130mm	SNLH 8	5 29/32 [150 mm]	19 11/16	3	1 5/8	16 9/16	—	13 1/2	Two 1 1/4	176
5 15/16 6 150 mm 155 mm 160 mm	S1 SNLH 515 S1 SNLH 600 S1 SNLH 150mm S1 SNLH 155mm S1 SNLH 160mm	SNLH 10	6 11/16 [170 mm]	21 5/8	3 3/4	2	18 7/8	—	15 5/16	Two 1 1/4	225
6 15/16 7 170 mm 180 mm	S1 SNLH 615 S1 SNLH 700 S1 SNLH 170mm S1 SNLH 180mm	SNLH 12	7 1/2 [190 mm]	25 3/16	4 3/4	2 3/16	23 1/4	1	16 3/4	Four 1	283

* Specify Suffix – FL for float bearing,
HD for held bearing

** Base to center height can be altered upon request

Special application bearings are available upon request.
‡ Housing width only

Dimensions in inches
Normal operating temperature for
standard bearings is 32°F to 212°F

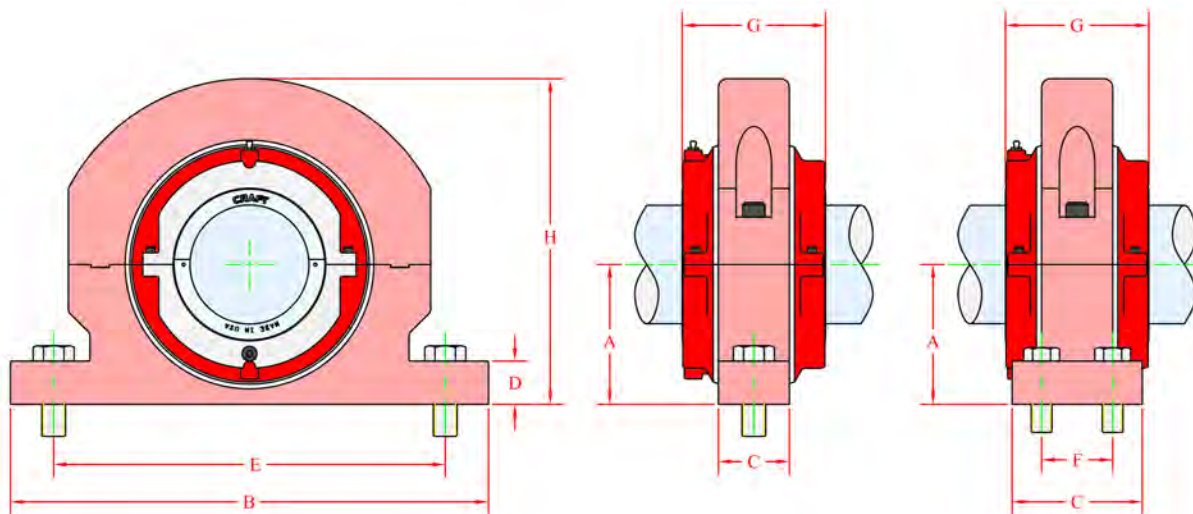

S1 Series Load Chart

S1 Series Load Chart

Bearing Group	MAX RPM	50 RPM		100 RPM		250 RPM		500 RPM		750 RPM		1000 RPM		1250 RPM		1500 RPM		2000 RPM		2500 RPM		3000 RPM		3500 RPM		4000 RPM	
		Pr	Pa	Pr	Pa	Pr	Pa	Pr	Pa	Pr	Pa	Pr	Pa	Pr	Pa	Pr	Pa	Pr	Pa	Pr	Pa	Pr	Pa	Pr	Pa	Pr	Pa
S1-108	5,420	2,997	778	2,434	778	1,849	778	1,502	570	1,330	380	1,220	285	1,141	228	1,080	190	991	143	927	114	877	95	838	81	805	71
S1-200	4,460	3,952	1,125	3,210	1,125	2,438	1,125	1,981	652	1,754	435	1,609	326	1,505	261	1,424	217	1,307	163	1,222	130	1,157	109	1,105	93	1,061	82
S1-208	3,750	4,376	1,243	3,554	1,243	2,700	1,243	2,193	702	1,942	468	1,781	351	1,666	281	1,577	234	1,447	176	1,353	140	1,281	117	1,223	100		
S1-300	3,190	6,447	2,004	5,237	2,004	3,978	1,732	3,231	866	2,861	577	2,625	433	2,455	346	2,324	289	2,132	217	1,994	173	1,888	144				
S1-308	2,740	8,113	2,637	6,590	2,637	5,006	1,812	4,066	906	3,600	604	3,303	453	3,089	362	2,924	302	2,683	227	2,509	181						
S1-400	2,400	11,065	3,653	8,987	3,653	6,827	2,208	5,546	1,104	4,910	736	4,504	552	4,213	442	3,988	368	3,659	276								
S1-408	2,140	13,656	4,731	11,092	4,731	8,426	2,616	6,844	1,308	6,060	872	5,559	654	5,199	523	4,922	436	4,515	327								
S1-500	1,940	15,733	5,570	12,779	5,570	9,708	2,740	7,885	1,370	6,982	913	6,405	685	5,990	548	5,671	457										
S1-508	1,780	17,436	6,240	14,162	6,240	10,758	2,868	8,739	1,434	7,738	956	7,098	717	6,638	574	6,285	478										
S1-600	1,670	18,925	7,088	15,372	7,088	11,678	3,048	9,485	1,524	8,399	1,016	7,704	762	7,205	610	6,822	508										
S1-608	1,550	21,012	7,952	17,067	7,952	12,965	3,197	10,531	1,599	9,325	1,066	8,554	799	8,000	639	7,574	533										
S1-700	1,465	22,579	8,904	18,340	8,445	13,932	3,378	11,316	1,689	10,020	1,126	9,192	845	8,597	676												
S1-800	1,320	23,896	9,922	19,410	8,459	14,745	3,384	11,977	1,692	10,605	1,128	9,728	846	9,098	677												
S1-900	1,190	26,329	11,154	21,386	8,566	16,246	3,426	13,196	1,713	11,685	1,142	10,718	857														
S1-1000	1,080	29,394	13,315	23,875	9,280	18,137	3,712	14,732	1,856	13,045	1,237	11,966	928														
S1-1100	990	33,808	15,185	27,461	9,679	20,861	3,872	16,944	1,936	15,004	1,291																
S1-1200	915	35,411	16,579	28,763	9,743	21,850	3,897	17,748	1,949	15,715	1,299																
S1-1300	866	38,418	18,169	31,205	10,072	23,705	4,029	19,254	2,014	17,049	1,343																
S1-1400	805	38,183	18,381	31,014	9,510	23,560	3,804	19,137	1,902	16,945	1,268																
S1-1500	753	43,966	21,080	35,711	10,540	27,128	4,216	22,035	2,108	19,511	1,405																
S1-1600	713	44,285	21,466	35,971	10,733	27,326	4,293	22,195	2,147																		

Radial Load: $Pr \leq \frac{Cr}{fd} \times \left(\frac{16667}{n \times L10} \right)^{3/10}$ Axial Load: $Pa \leq \frac{Ca \times SF}{n}$ or $.05 \times Co$, whichever is less
 SF = 1000 RPM for small bore (600 group and below)
 100 RPM for large bore (608 group and above)
 The above ratings are based upon a minimum life of 30,000 hours (L10), utilization of EP grease, and a service factor of 1.2 (fd).
 Cr = Dynamic Radial Load Rating
 Co = Static Radial Load Rating
 Ca = Dynamic Axial Load Rating
 L10 = Life Rating
 SF = Speed Factor
 n = RPM
 fd = Service Factor

Mounted Unit

BEARING DIMENSIONS

Shaft Diameter	Complete* Component	Pedestal Housing	A**	B	C‡	D	E		F	H	Bolts	Weight lbs.
							Minimum	Maximum				
2 3/16 2 1/4 2 7/16 2 1/2 55 mm 60 mm 65 mm	S2 BCH 203 S2 BCH 204 S2 BCH 207 S2 BCH 208 S2 BCH 55mm S2 BCH 60mm S2 BCH 65mm	PH 4	3 3/4	13	3	1 1/2	10 1/4	11	-	7 7/8	Two 3/4	39
2 11/16 2 3/4 2 15/16 3 70 mm 75 mm	S2 BCH 211 S2 BCH 212 S2 BCH 215 S2 BCH 300 S2 BCH 70mm S2 BCH 75mm	PH 5 (2B) PH 5 (4B)	4 13/32	15	3 1/2 5 1/2	1 3/4	12 3/16 12 3/8	13 3/16 13 3/8	- 3 1/2	10 1/16	Two 3/4 Four 3/4	66.6 74
3 3/16 3 1/4 3 7/16 3 1/2 80 mm 85 mm 90 mm	S2 BCH 303 S2 BCH 304 S2 BCH 307 S2 BCH 308 S2 BCH 80mm S2 BCH 85mm S2 BCH 90mm	PH 6 (2B) PH 6 (4B)	4 15/16	16 3/4	4 1/4 6	2	13 1/2 14	14 7/8 15	- 4	10 3/4	Two 3/4 Four 3/4	79.2 88
3 11/16 3 3/4 3 15/16 4 100 mm 105 mm	S2 BCH 311 S2 BCH 312 S2 BCH 315 S2 BCH 400 S2 BCH 100mm S2 BCH 105mm	PH 7	5 5/8	18 3/4	6 3/4	2 3/8	15 3/4	16 11/16	4 1/2	12 3/8	Four 3/4	118
4 3/16 4 1/4 4 7/16 4 1/2 110 mm 115 mm	S2 BCH 403 S2 BCH 404 S2 BCH 407 S2 BCH 408 S2 BCH 110mm S2 BCH 115mm	PH 8	6 3/8	20	7	1 1/2	7 1/4	18 3/16	4 3/4	14	Four 7/8	180
4 11/16 4 15/16 5 120 mm 125 mm 130 mm	S2 BCH 411 S2 BCH 415 S2 BCH 500 S2 BCH 120mm S2 BCH 125mm S2 BCH 130mm	PH 10	7 1/8	22	7	1 5/8	18 1/2	20 1/2	4 3/4	15 3/4	Four 7/8	234
5 3/16 5 7/16 5 1/2 140 mm	S2 BCH 503 S2 BCH 507 S2 BCH 508 S2 BCH 140mm	PH 20	8	24	7	2	21	22	4 3/4	18	Four 1	320
5 15/16 6 150 mm 155 mm	S2 BCH 515 S2 BCH 600 S2 BCH 150mm S2 BCH 155mm	PH 21	8 1/4	25	8	2	21 1/2	22 1/2	5	18	Four 1	374

* Specify Suffix – FL for float bearing,
HD for held bearing

Special application bearings are available upon request.
‡ Housing width only

Dimensions in inches
Normal operating temperature for
standard bearings is 32°F to 212°F

** Base to center height can be altered upon request

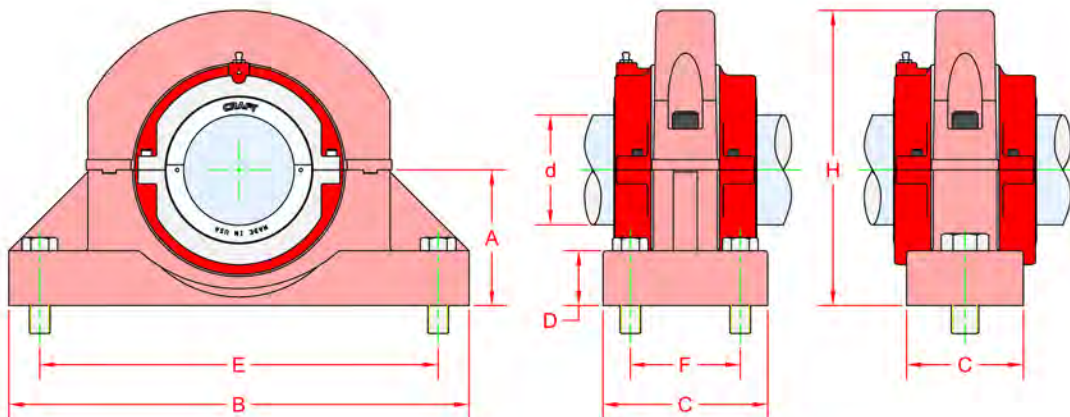

Cartridge Assembly

Shaft Diameter	Cartridge* Assembly	Cartridge	L	G‡	Weight lbs.	Grease Capacity
2 3/16 2 1/4 2 7/16 2 1/2 55 mm 60 mm 65 mm	S2 BC 203 S2 BC 204 S2 BC 207 S2 BC 208 S2 BC 55mm S2 BC 60mm S2 BC 65mm	S2 C 208	6 3/16	4 15/16	24.2	7.6 oz
2 11/16 2 3/4 2 15/16 3 70 mm 75 mm	S2 BC 211 S2 BC 212 S2 BC 215 S2 BC 300 S2 BC 70mm S2 BC 75mm	S2 C 300	7	5 1/2	34	10.5 oz
3 3/16 3 1/4 3 7/16 3 1/2 80 mm 85 mm 90 mm	S2 BC 303 S2 BC 304 S2 BC 307 S2 BC 308 S2 BC 80mm S2 BC 85mm S2 BC 90mm	S2 C 308	8	5 3/4	41.3	1.1 lbs
3 11/16 3 3/4 3 15/16 4 100 mm 105 mm	S2 BC 311 S2 BC 312 S2 BC 315 S2 BC 400 S2 BC 100mm S2 BC 105mm	S2 C 400	9 1/8	5 3/4	58	1.4 lbs
4 3/16 4 1/4 4 7/16 4 1/2 110 mm 115 mm	S2 BC 403 S2 BC 404 S2 BC 407 S2 BC 408 S2 BC 110mm S2 BC 115mm	S2 C 408	10 1/2	6 3/8	77.2	2.0 lbs
4 11/16 4 15/16 5 120 mm 125 mm 130 mm	S2 BC 411 S2 BC 415 S2 BC 500 S2 BC 120mm S2 BC 125mm S2 BC 130mm	S2 C 500	11 5/8	7 1/4	111.5	2.5 lbs
5 3/16 5 7/16 5 1/2 140 mm	S2 BC 503 S2 BC 507 S2 BC 508 S2 BC 140mm	S2 C 508	12 3/4	7 3/8	138.3	3.0 lbs
5 15/16 6 150 mm 155 mm	S2 BC 515 S2 BC 600 S2 BC 150mm S2 BC 155mm	S2 C 600	13 1/4	7 15/16	162	3.0 lbs

* Specify Suffix – FL for float bearing,
HD for held bearing

‡ Length through bore.

** Based on Axial Capacity at 1000 RPM.

Roller Bearing

Bearing*	Bearing Rating lbs.			Max RPM	Do	Wi	Wo	Weight lbs.
	Dynamic Cr	Static Co	Axial Ca**					
S2 B 203 S2 B 204 S2 B 207 S2 B 208 S2 B 55mm S2 B 60mm S2 B 65mm	33,580	42,860	473	3,450	5	2.844	1.531	7.7
S2 B 211 S2 B 212 S2 B 215 S2 B 300 S2 B 70mm S2 B 75mm	45,420	59,250	561	2,930	5.875	3.25	1.813	12.1
S2 B 303 S2 B 304 S2 B 307 S2 B 308 S2 B 80mm S2 B 85mm S2 B 90mm	57,430	79,580	666	2,550	6.688	3.528	1.906	17.6
S2 B 311 S2 B 312 S2 B 315 S2 B 400 S2B100mm S2B105mm	74,130	105,015	761	2,230	7.625	3.622	2.031	21.8
S2 B 403 S2 B 404 S2 B 407 S2 B 408 S2 B 110mm S2 B 115mm	91,410	131,140	857	1,980	9	3.938	2.25	38.9
S2 B 411 S2 B 415 S2 B 500 S2 B 120mm S2 B 125mm S2 B 130mm	111,320	162,690	951	1,780	10	4.5	2.5	55
S2 B 503 S2 B 507 S2 B 508 S2 B 140mm	133,640	197,690	1,060	1,630	10.75	4.625	2.625	58.3
S2 B 515 S2 B 600 S2 B 150mm S2 B 155mm	147,260	229,200	1,137	1,450	11.5	4.875	2.688	70.4

Dimensions in inches

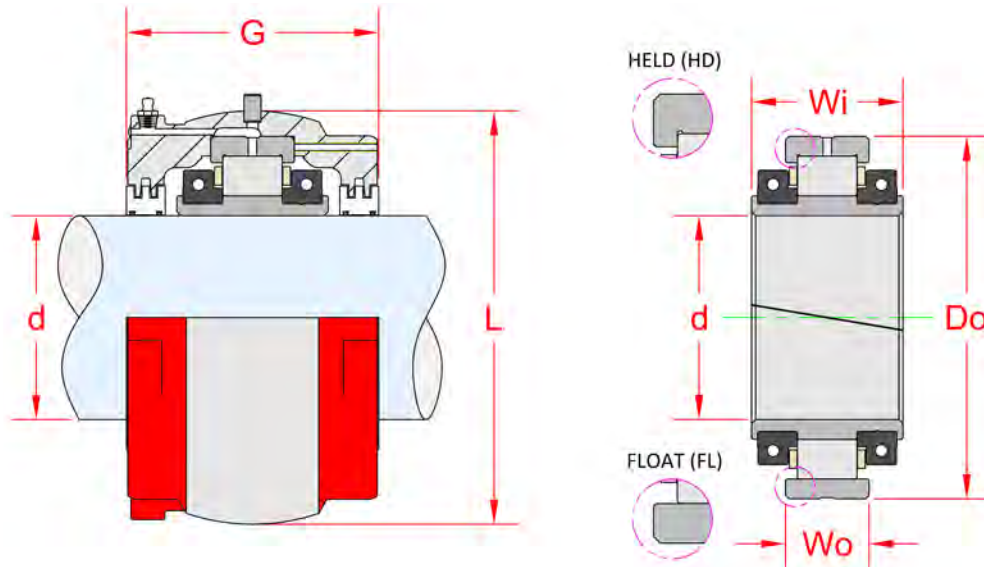

Mounted Unit

BEARING DIMENSIONS

Shaft Diameter	Complete* Component	Pedestal Housing	A**	B	C‡	D	E		F	H	Bolts	Weight lbs.
							Minimum	Maximum				
6 7/16 6 1/2 160 mm 170 mm	S2 BCH 607 S2 BCH 608 S2 BCH 160mm S2 BCH 170mm	PH 22	10 1/2	23 1/2	9 1/2	1 3/4	16 7/8	18 3/8	6 3/4	21	Four 1 1/4	407
6 15/16 7 180 mm	S2 BCH 615 S2 BCH 700 S2 BCH 180mm	PH 23	10 3/4	25	9 1/2	1 3/4	17 1/4	18 3/4	6 1/2	21 1/2	Four 1 1/4	478
7 1/2 7 15/16 8 190 mm 200 mm	S2 BCH 708 S2 BCH 715 S2 BCH 800 S2 BCH 190mm S2 BCH 200mm	PH 24	12	27	10 1/2	2	19 1/4	20 3/4	7 1/2	23 7/8	Four 1 1/4	646
8 1/2 9 220 mm 230 mm	S2 BCH 808 S2 BCH 900 S2 BCH 220mm S2 BCH 230mm	PH 25	12 3/4	29 1/2	11	2	20 7/8	22 3/8	7 1/2	25 1/4	Four 1 1/2	807
9 1/2 10 240 mm 260 mm	S2 BCH 908 S2 BCH 1000 S2 BCH 240mm S2 BCH 260mm	PH 26	14	32	11 1/2	2 1/8	22 3/4	24 1/4	8	28	Four 1 1/4	938
10 1/2 11 280 mm	S2 BCH 1008 S2 BCH 1100 S2 BCH 280mm	PH 27	14 7/8	36	13	2 3/8	20 1/4 28 1/4	21 3/4 29 3/4	10	30	Eight 1 1/4	1126
11 1/2 12 300 mm	S2 BCH 1108 S2 BCH 1200 S2 BCH 300mm	PH 28	15 1/2	37 3/4	13	2 3/8	21 1/2 29 1/2	23 31	10	31	Eight 1 1/4	1295
12 1/2 13 320 mm	S2 BCH 1208 S2 BCH 1300 S2 BCH 320mm	PH 29	16 1/2	40	11 1/2	2 1/2	23 1/4 31 1/4	24 13/16 32 13/16	8 1/4	33	Eight 1 1/4	1560
14 340 mm 360 mm	S2 BCH 1400 S2 BCH 340mm S2 BCH 360mm	PH 30	17 3/4	43	14 1/2	2 1/2	25 3/16 33 3/16	26 3/4 34 3/4	11	35 1/2	Eight 1 1/4	1742
15 380 mm	S2 BCH 1500 S2 BCH 380mm	PH 31	18 1/4	43	14 1/2	2 5/8	26 1/16 34 1/16	27 5/8 35 5/8	11	36 1/2	Eight 1 1/4	1853
15 1/2 16 400 mm	S2 BCH 1508 S2 BCH 1600 S2 BCH 400mm	PH 32	19 1/2	46	14 1/2	2 3/4	27 15/16 35 15/16	29 1/2 37 1/2	11	39	Eight 1 1/4	2200

* Specify Suffix – FL for float bearing,
HD for held bearing

Special application bearings are available upon request.
‡ Housing width only

Dimensions in inches
Normal operating temperature for
standard bearings is 32°F to 212°F

** Base to center height can be altered upon request

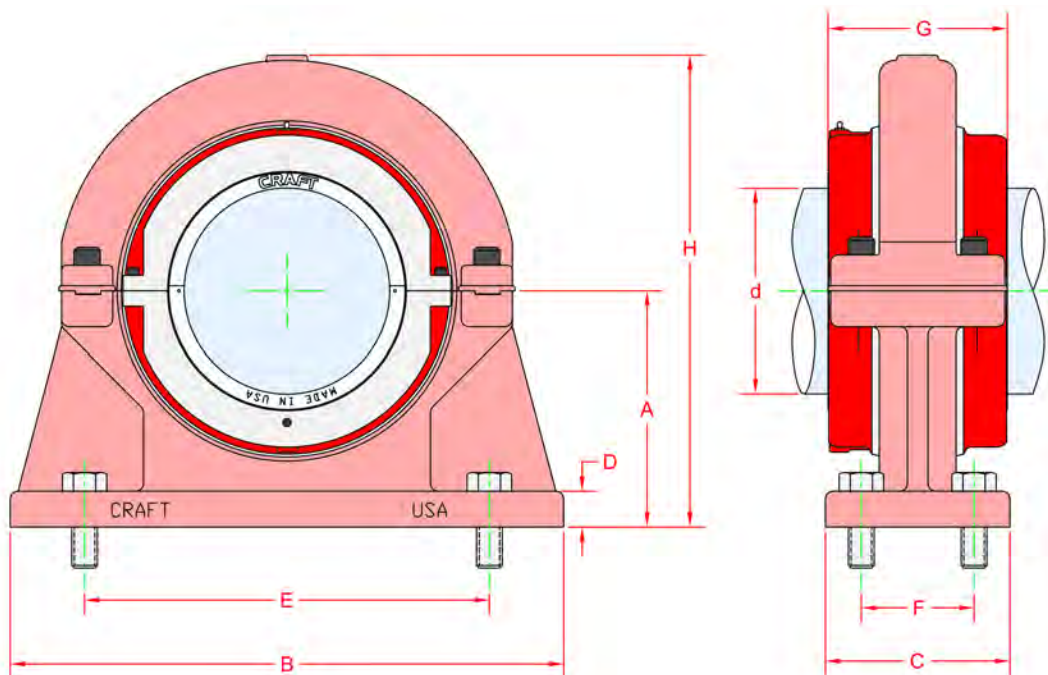

Cartridge Assembly

Shaft Diameter	Cartridge* Assembly	Cartridge	L	G‡	Weight lbs.	Grease Capacity
6 7/16 6 1/2 160 mm 170 mm	S2 BC 607 S2 BC 608 S2 BC 160mm S2 BC 170mm	S2 C 608	14 1/2	9 1/8	231	3.2 lbs
6 15/16 7 180 mm	S2 BC 615 S2 BC 700 S2 BC 180mm	S2 C 700	15	9 1/2	268	4.3 lbs
7 1/2 7 15/16 8 190 mm 200 mm	S2 BC 708 S2 BC 715 S2 BC 800 S2 BC 190mm S2 BC 200mm	S2 C 800	16 3/4	10 1/16	345	5.9 lbs
8 1/2 9 220 mm 230 mm	S2 BC 808 S2 BC 900 S2 BC 220mm S2 BC 230mm	S2 C 900	18	10 13/16	364	8.0 lbs
9 1/2 10 240 mm 260 mm	S2 BC 908 S2 BC 1000 S2 BC 240mm S2 BC 260mm	S2 C 1000	19 1/2	11 1/16	440	8.9 lbs
10 1/2 11 280 mm	S2 BC 1008 S2 BC 1100 S2 BC 280mm	S2 C 1100	20 3/4	11 13/16	525	10.4 lbs
11 1/2 12 300 mm	S2 BC 1108 S2 BC 1200 S2 BC 300mm	S2 C 1200	21 3/4	12 1/16	600	11.8 lbs
12 1/2 13 320 mm	S2 BC 1208 S2 BC 1300 S2 BC 320mm	S2 C 1300	23 1/8	13	690	16.0 lbs
14 340 mm 360 mm	S2 BC 1400 S2 BC 340mm S2 BC 360mm	S2 C 1400	24 3/4	13 1/2	800	15.9 lbs
15 380 mm	S2 BC 1500 S2 BC 380mm	S2 C 1500	25 1/2	13 1/2	882	17.0 lbs
15 1/2 16 400 mm	S2 BC 1508 S2 BC 1600 S2 BC 400mm	S2 C 1600	27	13 1/4	1105	20.0 lbs

* Specify Suffix – FL for float bearing,
HD for held bearing

‡ Length through bore.

** Based on Axial Capacity at 100 RPM.

Roller Bearing

Bearing*	Bearing Rating lbs.			Max RPM	Do	Wi	Wo	Weight lbs.
	Dynamic Cr	Static Co	Axial Ca**					
S2 B 607 S2 B 608 S2 B 160mm S2 B 170mm	156,150	237,651	10,902	1,407	12.5	5.5	3.281	93.5
S2 B 615 S2 B 700 S2 B 180mm	165,055	259,722	11,920	1,336	13	5.5	3.281	110
S2 B 708 S2 B 715 S2 B 800 S2 B 190mm S2 B 200mm	199,920	325,750	12,495	1,188	14.5	6.141	3.563	134
S2 B 808 S2 B 900 S2 B 220mm S2 B 230mm	216,740	371,520	13,045	1,091	15.5	6.402	3.563	148
S2 B 908 S2 B 1000 S2 B 240mm S2 B 260mm	245,900	427,520	13,757	990	17	6.668	3.813	187
S2 B 1008 S2 B 1100 S2 B 280mm	279,502	492,460	14,600	914	18.25	7.323	4	209
S2 B 1108 S2 B 1200 S2 B 300mm	300,990	555,066	15,185	850	19.5	7.594	4.063	297
S2 B 1208 S2 B 1300 S2 B 320mm	309,510	589,610	14,170	785	20.75	7.559	4.189	325
S2 B 1400 S2 B 340mm S2 B 360mm	359,685	682,815	16,050	737	22.25	7.784	4.563	405
S2 B 1500 S2 B 380mm	385,784	760,770	16,915	703	23	7.874	4.374	410
S2 B 1508 S2 B 1600 S2 B 400mm	428,110	849,650	17,990	665	24.25	7.874	4.563	463

Dimensions in inches

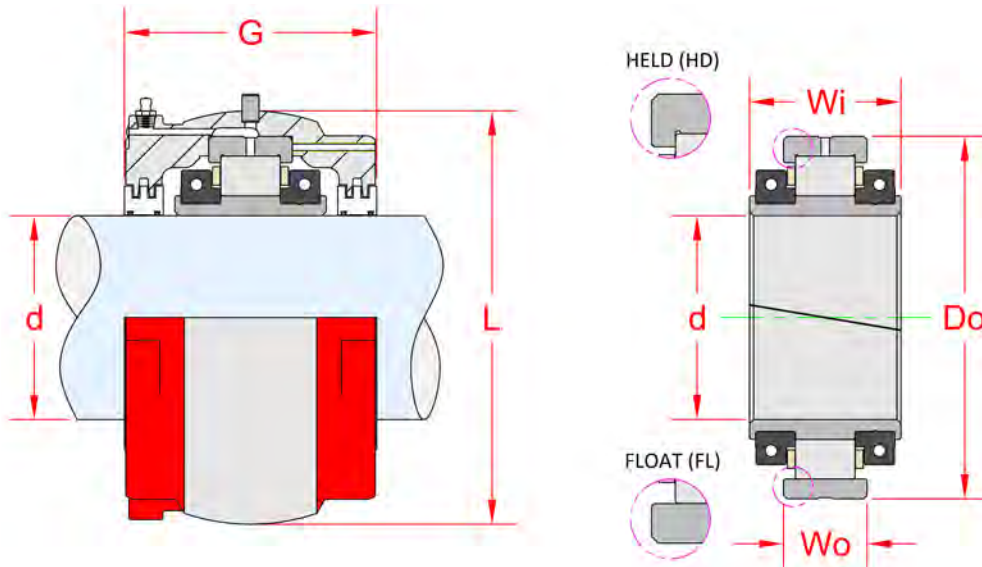

Mounted Unit

BEARING DIMENSIONS

Shaft Diameter	Complete* Component	Flange Housing	Y	K	X	Z	S	T	P	Bolts	Weight lbs.
2 3/16 2 1/4 2 7/16 2 1/2 55 mm 60 mm 65 mm	S2 BCF 203 S2 BCF 204 S2 BCF 207 S2 BCF 208 S2 BCF 55mm S2 BCF 60mm S2 BCF 65mm	FH 4	11 1/4	5 3/8	2 7/8	9 9/16	6 3/4	5/8	7 9/16	Four 1/2	49
2 11/16 2 3/4 2 15/16 3 70 mm 75 mm	S2 BCF 211 S2 BCF 212 S2 BCF 215 S2 BCF 300 S2 BCF 70mm S2 BCF 75mm	FH 5	13	5 7/8	3 1/8	10 3/4	7 5/8	3/4	8 1/2	Four 5/8	69
3 3/16 3 1/4 3 7/16 3 1/2 80 mm 85 mm 90 mm	S2 BCF 303 S2 BCF 304 S2 BCF 307 S2 BCF 308 S2 BCF 80mm S2 BCF 85mm S2 BCF 90mm	FH 6	14	6 1/4	3 3/8	11 7/8	8 3/8	3/4	9 5/8	Four 5/8	96
3 11/16 3 3/4 3 15/16 4 100 mm 105 mm	S2 BCF 311 S2 BCF 312 S2 BCF 315 S2 BCF 400 S2 BCF 100mm S2 BCF 105mm	FH 7	15	6 1/2	3 5/8	13 1/8	9 1/4	7/8	10 7/8	Four 5/8	119
4 3/16 4 1/4 4 7/16 4 1/2 110 mm 115 mm	S2 BCF 403 S2 BCF 404 S2 BCF 407 S2 BCF 408 S2 BCF 110mm S2 BCF 115mm	FH 8	17	7 1/16	3 7/8	14 3/4	10 7/16	7/8	12 3/8	Four 7/8	191
4 11/16 4 15/16 5 120 mm 125 mm 130 mm	S2 BCF 411 S2 BCF 415 S2 BCF 500 S2 BCF 120mm S2 BCF 125mm S2 BCF 130mm	FH 10	18 1/2	8 1/18	4 1/2	16 1/4	11 1/2	1	13 5/8	Four 1	242
5 3/16 5 7/16 5 1/2 140 mm	S2 BCF 503 S2 BCF 507 S2 BCF 508 S2 BCF 140mm	FH 20	20	8 3/16	4 3/8	17 1/2	12 3/8	1	14 7/8	Four 1	290
5 15/16 6 150 mm 155 mm	S2 BCF 515 S2 BCF 600 S2 BCF 150mm S2 BCF 155mm	FH 21	21	8 7/8	4 7/8	18 3/8	13	1	15 1/2	Four 1	340

*Specify Suffix - FL for float bearing,
HD for held bearing
Special application bearings are available upon request.

Dimensions in inches
Normal operating temperature for
standard bearings is 32°F to 212°F

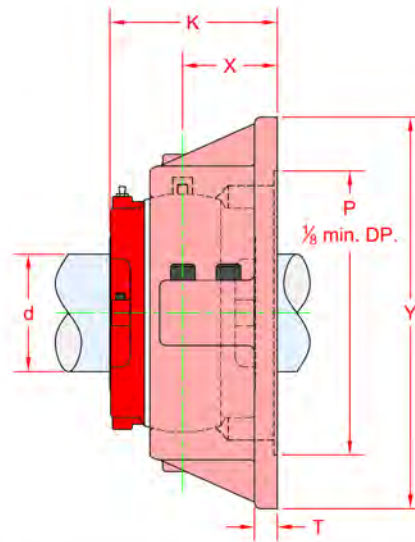
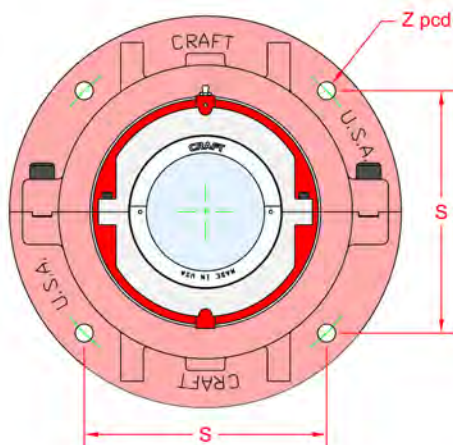

Mounted Unit

BEARING DIMENSIONS

Shaft Diameter	Complete* Component	Flange Housing	Y	K	X	Z	S	T	P	Bolts	Weight lbs.
6 7/16 6 1/2 160 mm 170 mm	S2 BCF 607 S2 BCF 608 S2 BCF 160mm S2 BCF 170mm	FH 22	23	9 7/16	4 7/8	20	14 1/8	1 1/8	16 7/8	Four 1 1/4	412
6 15/16 7 180 mm	S2 BCF 615 S2 BCF 700 S2 BCF 180mm	FH 23	23 1/2	9 7/8	5 1/8	20 5/8	14 9/16	1 1/4	17 1/2	Four 1 1/4	509
7 1/2 7 15/16 8 190 mm 200 mm	S2 BCF 708 S2 BCF 715 S2 BCF 800 S2 BCF 190mm S2 BCF 200mm	FH 24	25 1/2	10 3/8	5 3/8	22 1/2	15 13/16	1 1/4	19 3/8	Four 1 1/4	704
8 1/2 9 220 mm 230 mm	S2 BCF 808 S2 BCF 900 S2 BCF 220mm S2 BCF 230mm	FH 25	28	11 1/8	5 3/4	24 3/8	17 1/4	1 3/8	20 3/4	Four 1 1/2	771
9 1/2 10 240 mm 260 mm	S2 BCF 908 S2 BCF 1000 S2 BCF 240mm S2 BCF 250mm	FH 26	29	11 3/8	5 7/8	26	18 3/8	1 1/2	22 3/8	Four 1 1/2	825
10 1/2 11 280 mm	S2 BCF 1008 S2 BCF 1100 S2 BCF 280mm	FH 27	30	12 1/8	6 1/4	26 7/8	19	1 1/2	23 3/4	Eight 1 1/4	957
11 1/2 12 300 mm	S2 BCF 1108 S2 BCF 1200 S2 BCF 300mm	FH 28	31	12 3/8	6 3/8	27 7/8	19 11/16	1 5/8	24 3/4	Eight 1 1/4	1082
12 1/2 13 320 mm	S2 BCF 1208 S2 BCF 1300 S2 BCF 320mm	FH 29	36	14	7 1/2	31 1/2	22 1/4	1 3/4	26 3/4	Eight 1 1/4	1400

*Specify Suffix – FL for float bearing,
HD for held bearing
Special application bearings are available upon request.

Dimensions in inches
Normal operating temperature for
standard bearings is 32°F to 212°F

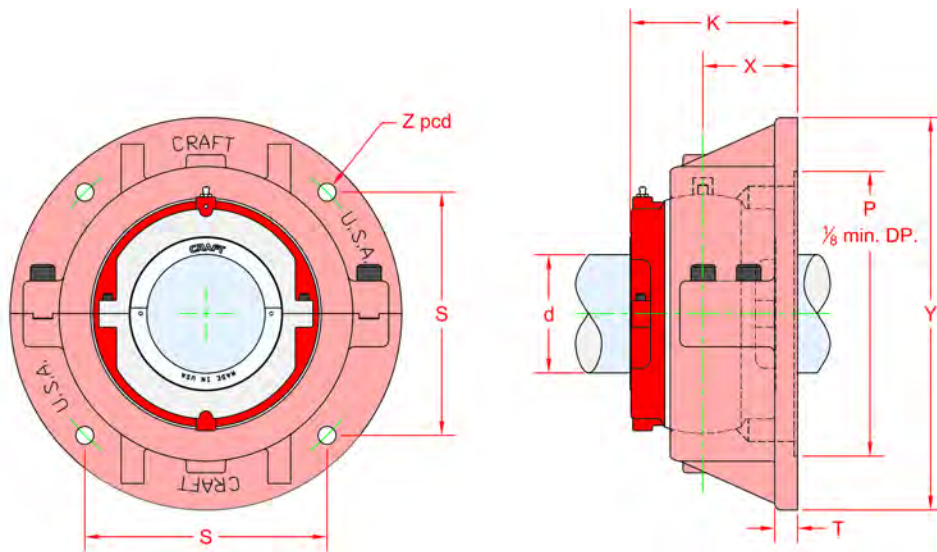

Mounted Unit

BEARING DIMENSIONS

Shaft Diameter	Complete* Component	Pedestal Housing	A**	B	C‡	D	E		F	H	Bolts	Weight lbs.
							Minimum	Maximum				
2 11/16 2 3/4 2 15/16 3 70 mm 75 mm	S2 SAFH 211 S2 SAFH 212 S2 SAFH 215 S2 SAFH 300 S2 SAFH 70mm S2 SAFH 75mm	SAF517	3 3/4	13	3 1/2	1 1/16	9 7/8	11	2 1/8	9 3/8	Four 5/8	56
3 3/16 3 1/4 3 7/16 3 1/2 80 mm 85 mm 90 mm	S2 SAFH 303 S2 SAFH 304 S2 SAFH 307 S2 SAFH 308 S2 SAFH 80mm S2 SAFH 85mm S2 SAFH 90mm	SAF520	4 1/2	15 1/4	4 3/8	1 3/4	11 5/8	13 1/8	2 3/8	10 5/16	Four 3/4	75
3 11/16 3 3/4 3 15/16 4 100 mm 105 mm	S2 SAFH 311 S2 SAFH 312 S2 SAFH 315 S2 SAFH 400 S2 SAFH 100mm S2 SAFH 105mm	SAF522	4 15/16	16 1/2	4 3/4	2	12 5/8	14 1/2	2 3/4	11 11/16	Four 3/4	120
4 3/16 4 1/4 4 7/16 4 1/2 110 mm 115 mm	S2 SAFH 403 S2 SAFH 404 S2 SAFH 407 S2 SAFH 408 S2 SAFH 110mm S2 SAFH 115mm	SAF526	6	18 3/8	5 1/8	2 3/8	14 5/8	16	3 1/4	13 5/8	Four 7/8	180
4 11/16 4 15/16 5 120 mm 125 mm 130 mm	S2 SAFH 411 S2 SAFH 415 S2 SAFH 500 S2 SAFH 120mm S2 SAFH 125mm S2 SAFH 130mm	SAF528	6	20 1/8	5 7/8	2 3/8	16	17 1/8	3 3/8	14 5/8	Four 1	225
5 3/16 5 7/16 5 1/2 140 mm	S2 SAFH 503 S2 SAFH 507 S2 SAFH 508 S2 SAFH 140mm	SAF532	6 11/16	22	6 1/4	2 11/16	17 3/8	19 1/4	3 3/4	16 11/16	Four 1	290
5 15/16 6 150 mm 155 mm	S2 SAFH 515 S2 SAFH 600 S2 SAFH 150mm S2 SAFH 155mm	SAF534	7 1/16	24 3/4	6 3/4	2 3/16	19 3/8	21 5/8	4 1/4	16 13/16	Four 1	335

* Specify Suffix – FL for float bearing.
HD for held bearing
** Base to center height can be altered upon request

Special application bearings are available upon request.
‡ Housing width only

Dimensions in inches
Normal operating temperature for standard bearings is 32°F to 212°F

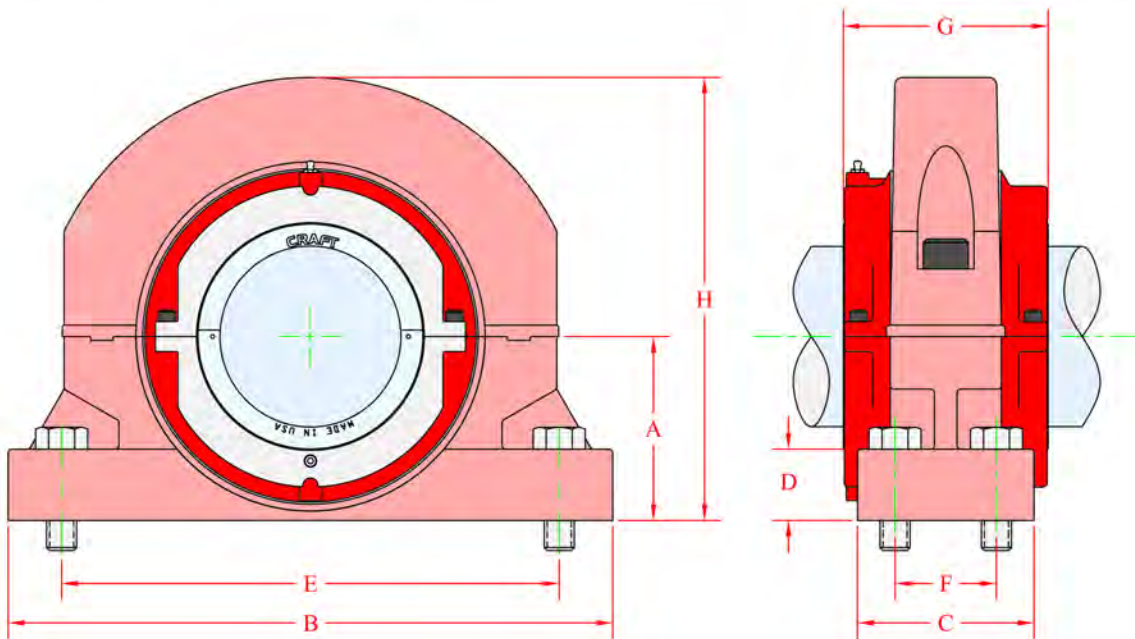

Mounted Unit

BEARING DIMENSIONS

Shaft Diameter	Complete* Component	Pedestal Housing	A**	B	C‡	D	E		F	H	Bolts	Weight lbs.
							Minimum	Maximum				
5 15/16 6 150 mm 155 mm	S3 BCH 515 S3 BCH 600 S3 BCH 150mm S3 BCH 155mm	PH 310	10	26 1/4	8	2 1/4	21 1/4	22 3/4	4 3/4	21	Four 1 1/4	698
6 7/16 6 1/2 160 mm 170 mm	S3 BCH 607 S3 BCH 608 S3 BCH 160mm S3 BCH 170mm	PH 311	10 1/2	29	9	2 3/8	24	25 1/2	5 1/2	22 1/2	Four 1 1/4	788
6 15/16 7 180 mm	S3 BCH 615 S3 BCH 700 S3 BCH 180mm	PH 312	11	30	10	2 1/2	24 1/4	25 3/4	6	22 7/8	Four 1 1/4	890
7 15/16 8 190 mm 200 mm	S3 BCH 715 S3 BCH 800 S3 BCH 190mm S3 BCH 200mm	PH 313	12 1/4	33	10 1/2	2 5/8	24 1/4	25 3/4	6 3/4	25 3/4	Four 1 1/2	1189
8 1/2 9 220 mm 230 mm	S3 BCH 808 S3 BCH 900 S3 BCH 220mm S3 BCH 230mm	PH 314	13 3/4	37 1/2	11	3	28 1/4	29 3/4	7	28 3/4	Four 1 3/4	1659
9 1/2 10 240 mm 260 mm	S3 BCH 908 S3 BCH 1000 S3 BCH 240mm S3 BCH 260mm	PH 315	15 1/2	36	16	3	25 5/8	27 1/8	12	31	Four 1 3/4	1890
11 280 mm	S3 BCH 1100 S3 BCH 280mm	PH 316	14 1/2	37	11	2 3/4	19 28 1/2	20 1/2 30	7	30 3/4	Eight 1 1/2	1386
11 1/2 12 300 mm	S3 BCH 1108 S3 BCH 1200 S3 BCH 300mm	PH 317	18	43	16 1/2	3	25 3/4 33 3/4	27 1/4 35 1/4	13	36	Eight 1 1/2	2625
13 320 mm	S3 BCH 1300 S3 BCH 320mm	PH 318	20 13/32	47	14	3	29 3/16 37 11/16	30 3/4 39 1/4	10 1/2	40 3/4	Eight 1 1/2	2725
14 340 mm 360 mm	S3 BCH 1400 S3 BCH 340mm S3 BCH 360mm	PH 319	18 1/2	48	12 1/2	3 1/4	24 7/8 35 3/8	27 37 1/2	7 1/2	39 1/2	Eight 1 1/2	2530
15 380 mm	S3 BCH 1500 S3 BCH 380mm	PH 320	22	50	15 1/2	3 9/16	30 11/16 39 11/16	32 3/4 41 3/4	11 1/2	44	Eight 1 1/2	3700

* Specify Suffix – FL for float bearing, HD for held bearing

** Base to center height can be altered upon request

Special application bearings are available upon request.
‡ Housing width only

Dimensions in inches
Normal operating temperature for standard bearings is 32°F to 212°F

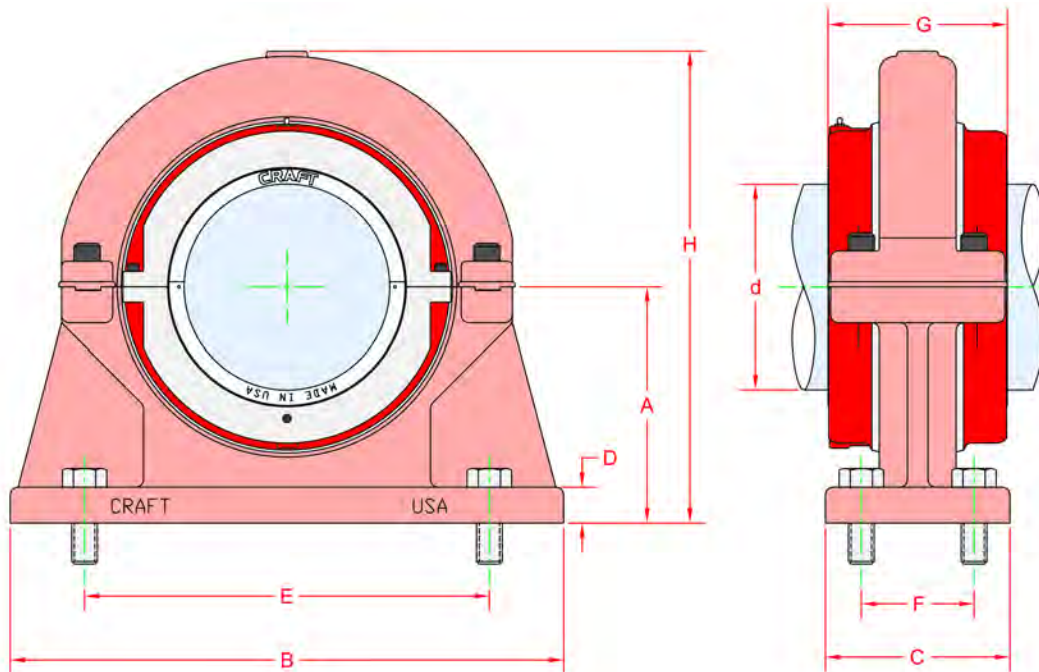

Cartridge Assembly

Shaft Diameter	Cartridge* Assembly	Cartridge	L	G‡	Weight lbs.	Grease Capacity
5 15/16 6 150 mm 155 mm	S3 BC 515 S3 BC 600 S3 BC 150mm S3 BC 155mm	S3 C 600	15 1/2	10	305	6.2 lbs
6 7/16 6 1/2 160 mm 170 mm	S3 BC 607 S3 BC 608 S3 BC 160mm S3 BC 170mm	S3 C 608	16 5/8	10 9/16	368	8.4 lbs
6 15/16 7 180 mm	S3 BC 615 S3 BC 700 S3 BC 180mm	S3 C 700	17	11 3/16	398	9.7 lbs
7 15/16 8 190 mm 200 mm	S3 BC 715 S3 BC 800 S3 BC 190mm S3 BC 200mm	S3 C 800	19 1/4	11 13/16	514	12.3 lbs
8 1/2 9 220 mm 230 mm	S3 BC 808 S3 BC 900 S3 BC 220mm S3 BC 230mm	S3 C 900	21 1/2	13 3/16	719	15.2 lbs
9 1/2 10 240 mm 260 mm	S3 BC 908 S3 BC 1000 S3 BC 240mm S3 BC 260mm	S3 C 1000	22	13 3/16	747	18.4 lbs
11 280 mm	S3 BC 1100 S3 BC 280mm	S3 C 1100	22 1/2	14 1/16	927	22.3 lbs
11 1/2 12 300 mm	S3 BC 1108 S3 BC 1200 S3 BC 300mm	S3 C 1200	25 1/4	14 9/16	1123	24.7 lbs
13 320 mm	S3 BC 1300 S3 BC 320mm	S3 C 1300	28 1/4	16 1/2	1300	26.5 lbs
14 340 mm 360 mm	S3 BC 1400 S3 BC 340mm S3 BC 360mm	S3 C 1400	27 3/4	17	1550	33.5 lbs
15 380 mm	S3 BC 1500 S3 BC 380mm	S3 C 1500	30 1/2	17 1/4	1800	35.5 lbs

* Specify Suffix – FL for float bearing,
HD for held bearing
** Based on Axial Capacity at 100 RPM.

‡ Length through bore.

Dimensions in inches

Roller Bearing

Bearing*	Bearing Rating lbs.			Max RPM	Do	Wi	Wo	Weight lbs.
	Dynamic Cr	Static Co	Axial Ca**					
S3 B 515 S3 B 600 S3 B 150mm S3 B 155mm	237,320	339,895	15,892	1,407	13	6.299	3.813	131
S3 B 607 S3 B 608 S3 B 160mm S3 B 170mm	237,082	360,353	15,455	1,305	14	6.72	4.063	169
S3 B 615 S3 B 700 S3 B 180mm	250,835	385,050	15,607	1,227	14.75	7.008	4.28	184
S3 B 715 S3 B 800 S3 B 190mm S3 B 200mm	296,110	461,510	16,940	1,105	16.5	7.52	4.656	244
S3 B 808 S3 B 900 S3 B 220mm S3 B 230mm	367,235	585,970	18,644	972	18.5	8.346	5.185	342
S3 B 908 S3 B 1000 S3 B 240mm S3 B 260mm	366,590	592,300	17,815	920	19	8.307	4.906	347
S3 B 1100 S3 B 280mm	434,343	750,975	19,360	870	19.5	9.606	5.5	428
S3 B 1108 S3 B 1200 S3 B 300mm	442,230	763,473	19,520	785	22	9.606	5.5	551
S3 B 1300 S3 B 320mm	519,800	876,970	20,385	710	24.5	10.709	6.315	710
S3 B 1400 S3 B 340mm S3 B 360mm	572,777	1,021,430	21,750	700	24.25	10.984	6.22	710
S3 B 1500 S3 B 380mm	632,590	1,137,590	22,840	636	27	11.496	6.563	960

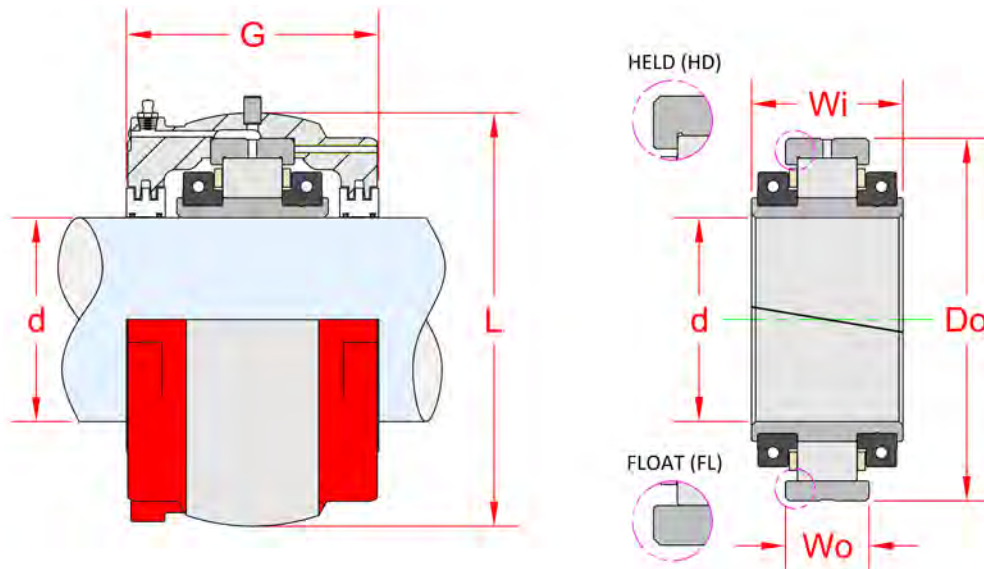

Equipment type/application: _____

Shaft diameter: _____ Current bearing type and model number: _____

Shaft speed: _____ Motor H.P.: _____ Ambient temperature: _____

Type of drive: Direct drive Belt drive Gear drive Gear reduction (Ratio)

Radial load: _____ Axial load: _____ Shaft temperature: _____

Service duty (24/7, etc.): _____ Life requirements: _____

Environment: Dirty Wet Caustic Acidic Neutral

Additional Information for Fan Application: Single inlet, over hung load: _____

Double inlet, center hung load: _____ Wheel and shaft weight: _____

Air temperature inside fan: _____ Fan inlet diameter: _____

Static pressure in inches of water (fan spec sheet) _____ (S.P.W.G.)

Comments, special considerations, return contact information:

Please contact Craft Bearing if you have any questions or if we may be of further service.

THANK YOU

CRAFT
Bearing Company Inc.
5000 Chestnut Avenue
Newport News, VA 23605

PHONE +1 (757) 247-6000
FAX +1 (757) 247-6300
EMAIL info@craftbearing.com
WEBSITE www.craftbearing.com

The Split Makes the Difference

MADE IN THE U.S.A.

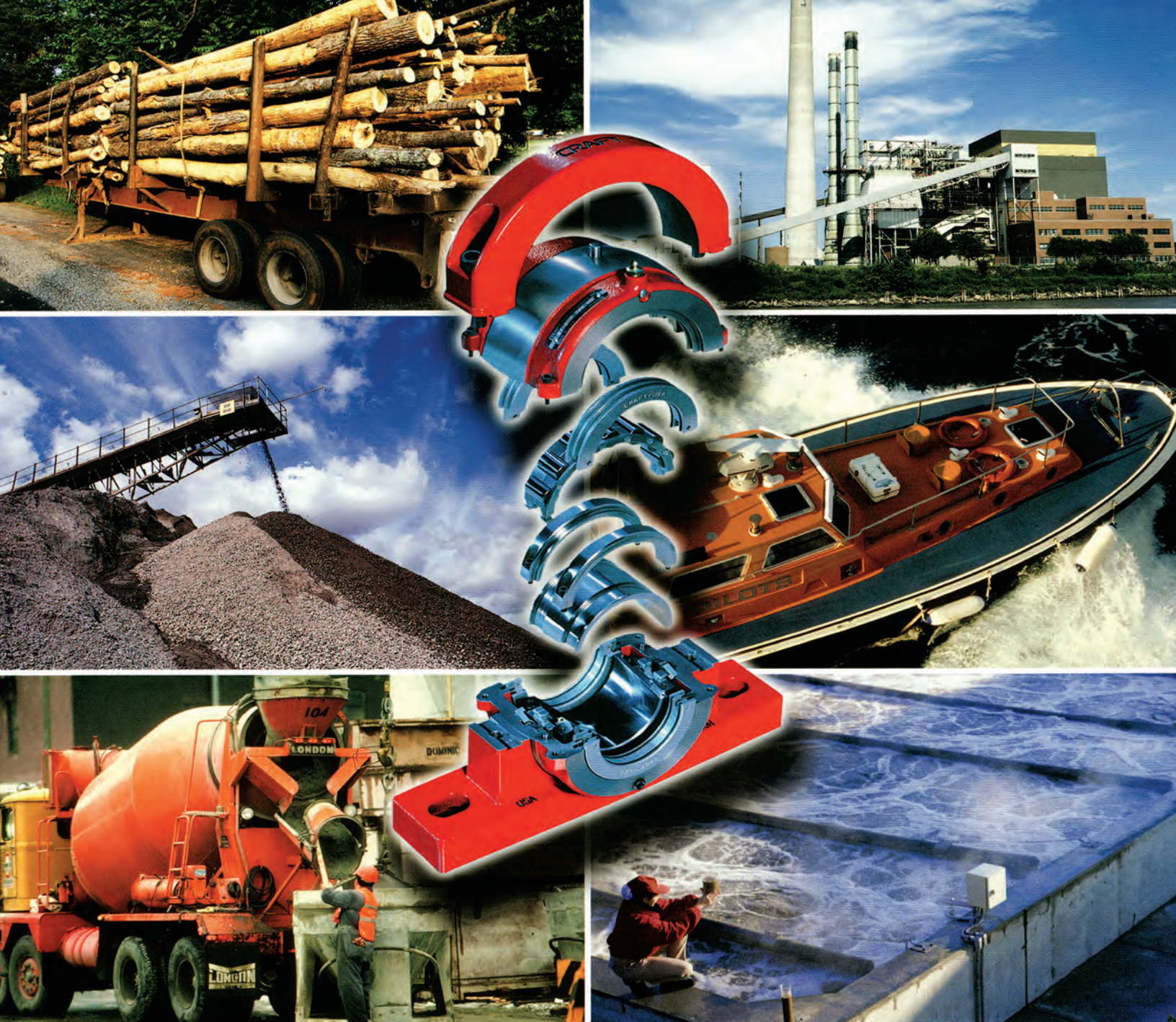

It's surprising where you can find Craft Bearings.

Craft Bearing exemplifies all that is fine in American craft, so it shouldn't surprise you to find our split roller bearings everywhere you go.

Lumber mills, mines, cement, power and waste/water treatment plants, and the marine industry – they all utilize Craft bearings. Why? Because of the quality and reliability of our American-made bearings.

Engineers appreciate the ease of installation and simple repair capability. And companies benefit from the reduced downtime between repairs and the resulting improvements to their bottom line.

Good reasons why distributors should put American Craft to work today.

- Standard base-to-center height
- Metric, special applications and custom bearings available
- Bore sizes from 1-7/16" to 32", same day shipment through 12"
- Ductile iron castings standard
- Complete technical support and rapid response to special orders and sizes
- 100% distributor support and incentive programs
- Craft bearings are directly interchangeable with foreign split bearings
- Made in USA

CRAFT
Bearing Company Inc.



5000 Chestnut Avenue ■ Newport News, VA 23605

PHONE (757) 247-6000
FAX (757) 247-6300

EMAIL info@craftbearing.com
WEBSITE www.craftbearing.com

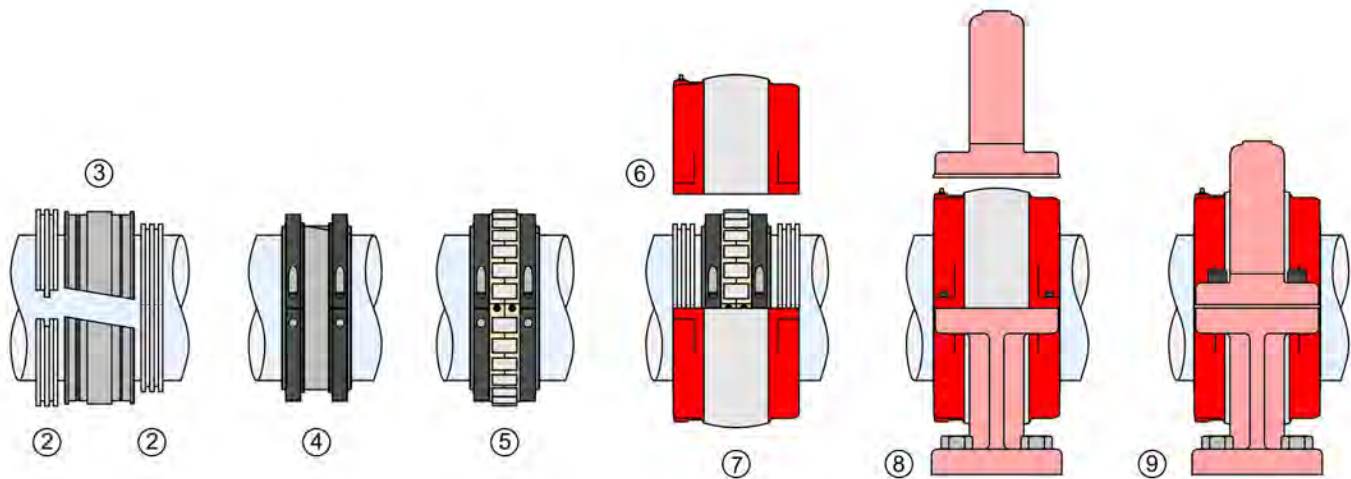

Assembly Preparation

Confirm proper bearing selection has been made. Check shaft journal for roundness and size. Ensure that the bearing and surrounding work areas are free of dirt and other contaminants.

Assembly (See Drawings Above)

1. Dismantle pillow block and clean parts with a government-approved solvent. It is not necessary to remove outer race from cartridge.
2. Apply grease between the O-ring centers before assembling the triple labyrinth (TL) seal. Install the TL seal and move to the outer perimeter of the bearing journal.
3. Position inner race in proper location observing matching marks.
4. Fit the clamping collars at approximately 45° from the inner race joints; insure that there is an equal gap at the inner race joints. Tap down clamping collars with a mallet and tighten the fine thread, high tensile screws equally, repeating until collars are properly seated.
5. Remove packing fasteners and ensure that provided "nyloc" screws are used to secure cage halves at joints. Coat the inner race and roller cage assembly with liberal amounts of grease. Install roller cage assembly, making sure that the cage clips or nyloc screws are securely in place.
6. Position seals so that they are in alignment with the grooves of the cartridge. Apply grease to the two grooves that form the outside diameter of the seals. This serves to lubricate the running surfaces of the seals and cartridge and seals the bearing stopping contaminants from working their way through the labyrinth and entering the bearing.
7. At this time, coat the running surface of the outer race with grease. Never assemble bearing dry, load carrying surfaces must be lubricated during assembly. Check cartridge match marks carefully, then assemble cartridge.
8. After cartridge halves are assembled, coat the spherical outside diameter of the cartridge and the bore of the housing with a graphite compound. Introduce the required amount of lubricant in the cartridge assembly.
9. Place the housing base into position, insuring that the bottom of the base is level and supported 100%. Loosely install the housing cap.
10. Rotate the shaft to align the cartridge assembly within the housing. Tighten the housing cap screws.

(Disassembly is in reverse)

NOTE: Before shafting is jacked up, all housing cap bolts should be backed off.

Warranty

Craft Bearing Company, Inc. will replace or repair any part or parts of Craft bearings that fail due to defective materials or workmanship that are returned to its factory within one year of delivery to the original purchaser. This constitutes Craft's only warranty in connection with the sale, is in lieu of all other warranties, expressed or implied, oral or written, and Craft shall have no responsibility for consequential or other damages. No employee, distributor, or agent is authorized to give any other warranty on behalf of Craft.

CRAFT
Bearing Company Inc.

5000 Chestnut Avenue
Newport News, VA 23605

PHONE +1 (757) 247-6000
FAX +1 (757) 247-6300
EMAIL info@craftbearing.com
WEBSITE www.craftbearing.com

Publication Data

This publication was created with intent to provide accurate information. Craft does not assume liability for any errors or omissions. Weights are estimates. Specifications subject to change without notice.

©2017 Craft Bearing Company, Inc.
Patents Pending